

PV/THERMAL COLLECTORS

Yiannis TRIPANAGNOSTOPOULOS

Assoc. Professor in Physics Department University of Patras, Greece
Tel: +30 2610 997472, e-mail: yiantrip@physics.upatras.gr

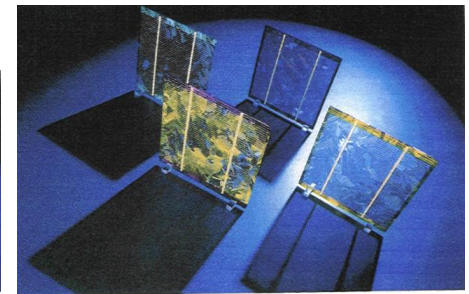

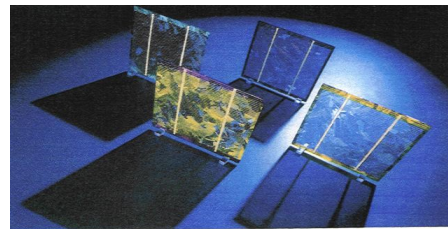
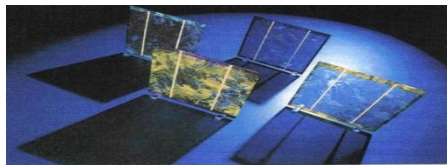

Patra



Patra: The gate of Greece to Europe



Solar Energy Laboratory

Is established at the Physics Department and has an experience in education and research for 35 years

Activities:

Solar collectors
Photovoltaics
small wind turbines
energy and building
greenhouses

ICS Type solar water heaters



Simple and low cost solar water heaters

Efficient in water heating

Satisfactory preservation of hot water temperature

Aesthetical integration on buildings

Booster reflectors to improve energy performance



The reflectors increase the solar input achieving higher thermal output at higher operating temperatures.



Solar collectors with colored absorbers



Solar collectors with absorbers of different color than black could be an interesting solution for the wider application of solar energy systems

These collectors are of lower thermal efficiency than that of the usual black collectors because of the lower absorptance

Stationary concentrating CPC solar collectors

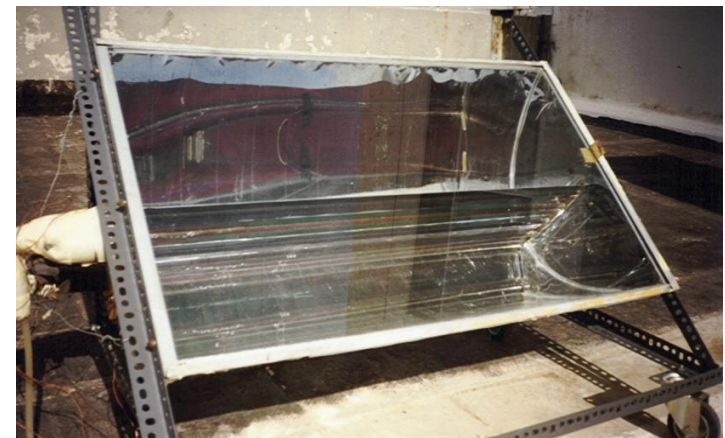
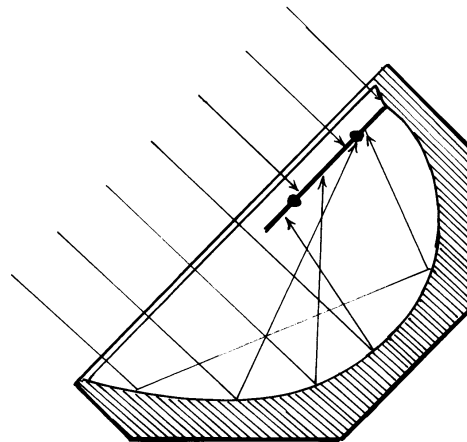
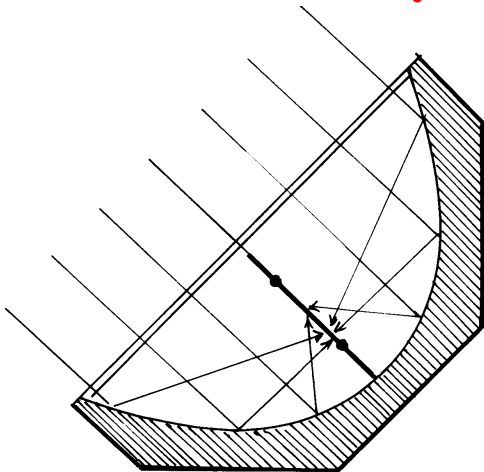

Hybrid PV/T Systems

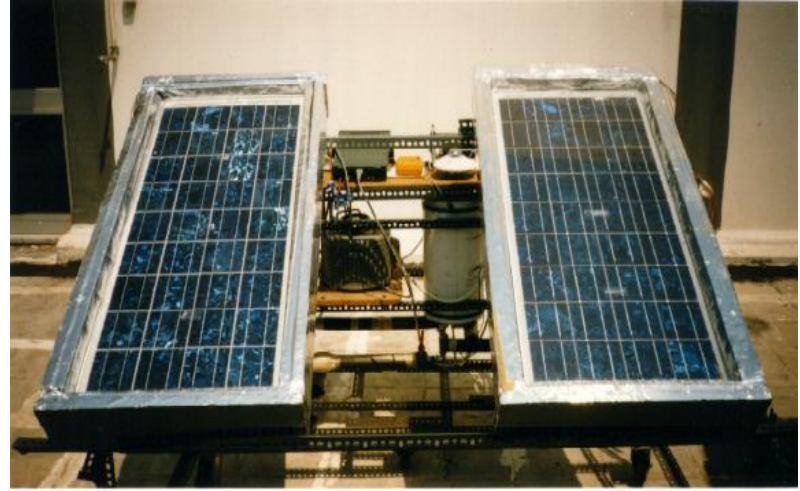

a PV / WATER

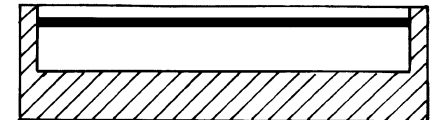

c PV / AIR

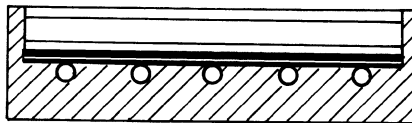

b PV / WATER + GL



d PV / AIR + GL

CROSS SECTION OF STUDIED PV/T SYSTEMS

Fresnel lenses for illumination and temperature control

Fresnel lenses are solar radiation concentrators with low volume and weight and low cost. They can separate the direct from the diffuse solar radiation and it makes them suitable for illumination control in the building interior space, providing light without sharp contrasts.

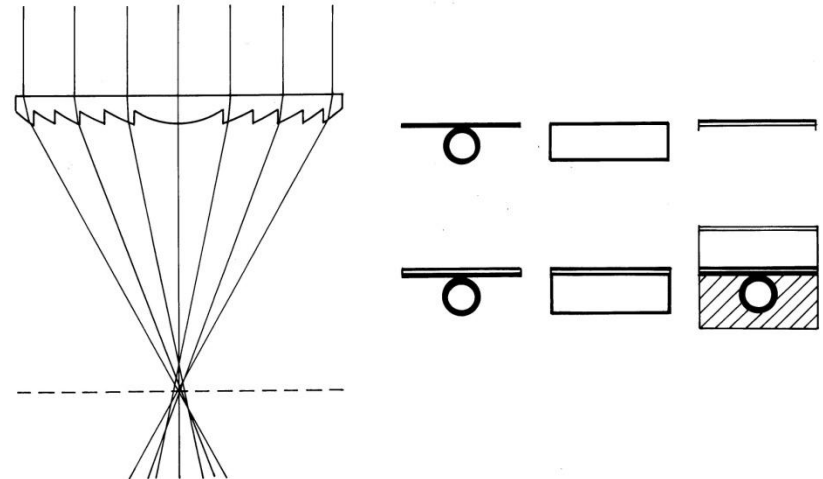
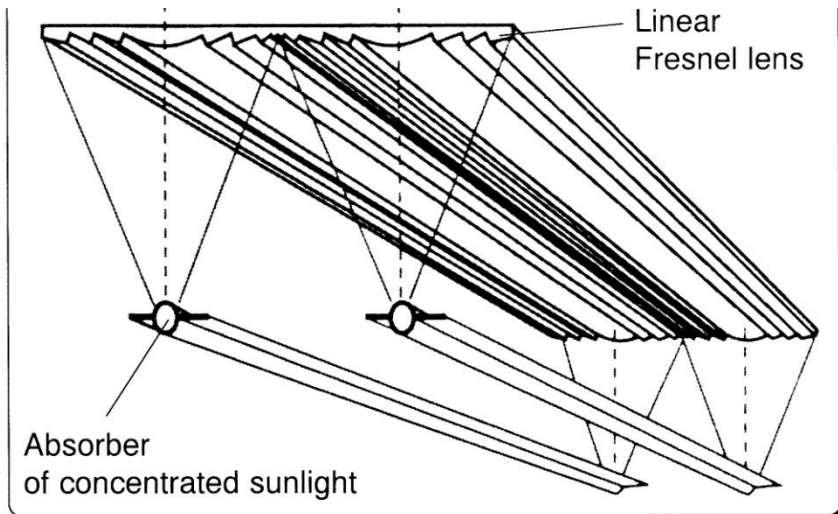

The surplus solar energy can be extracted and used to cover building electrical and thermal needs.



Solar Thermal

Domestic Hot Water



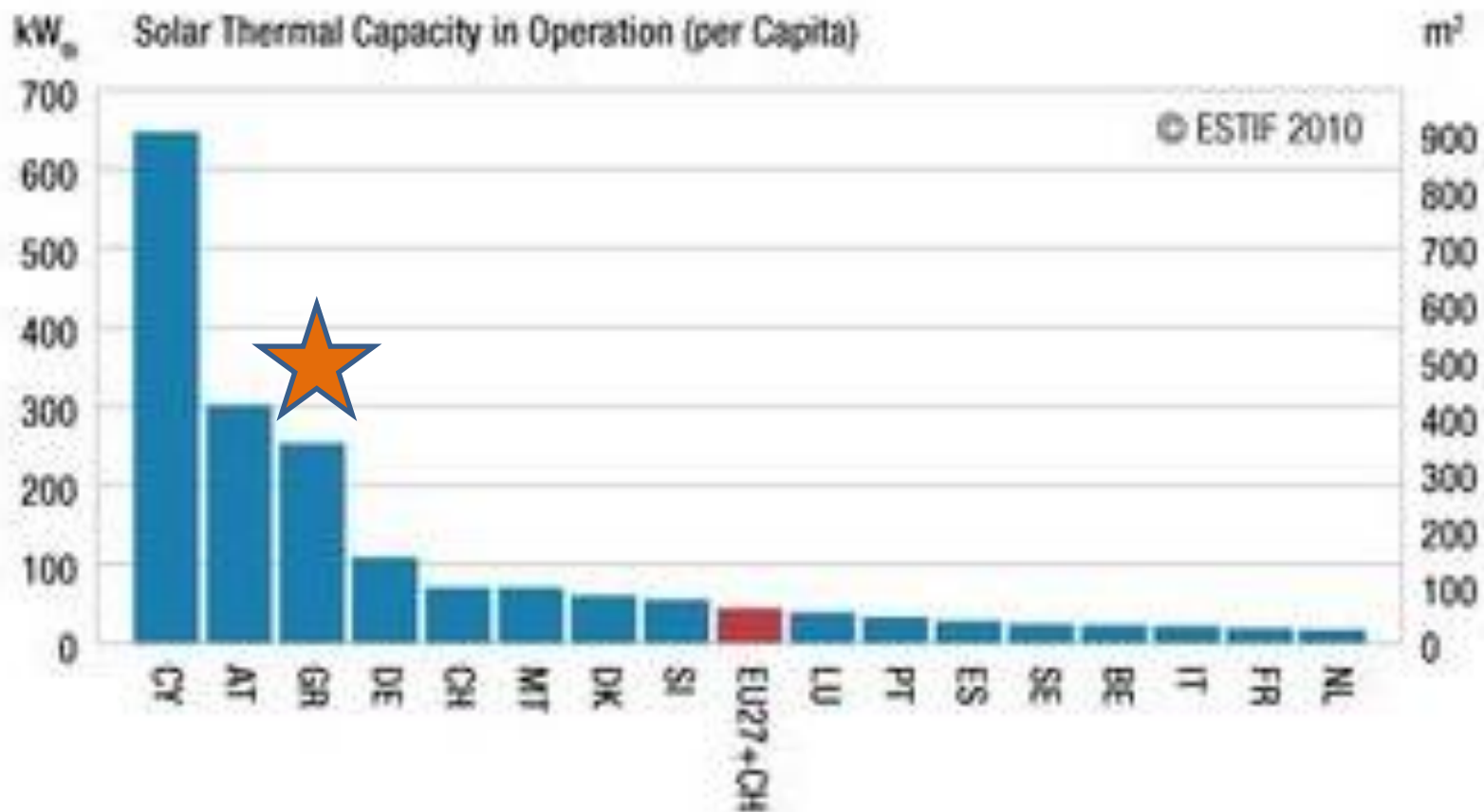

Installed solar thermal collectors per capita



Flat plate collector, vacuum collector, thermosiphonic collector, parabolic trough, Fresnel reflector and Fresnel lens concentrating collector.

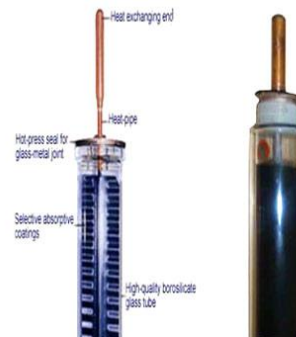
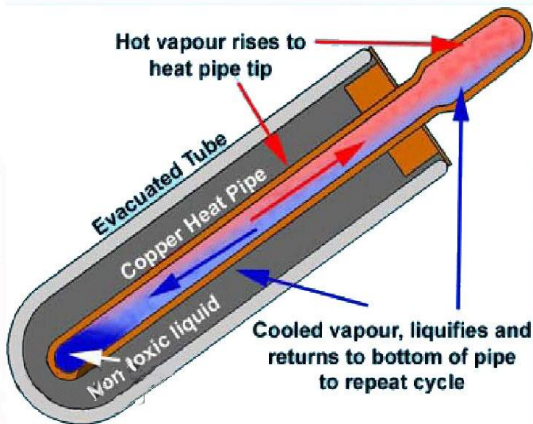



Solar Thermal systems



Application examples of solar thermal collectors



Solar Thermal systems

Application examples of solar thermal collectors



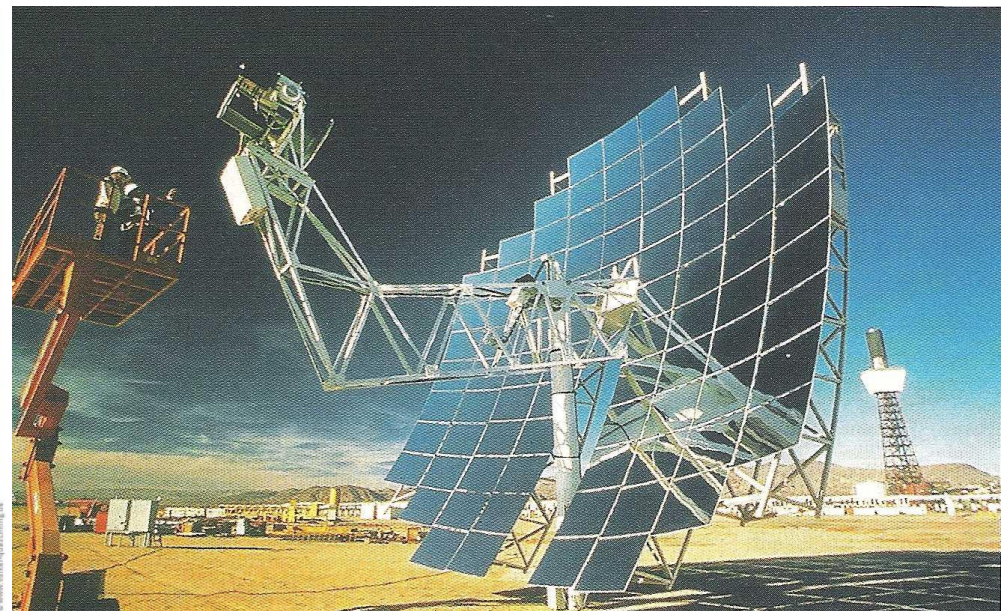

Concentrating solar thermal systems

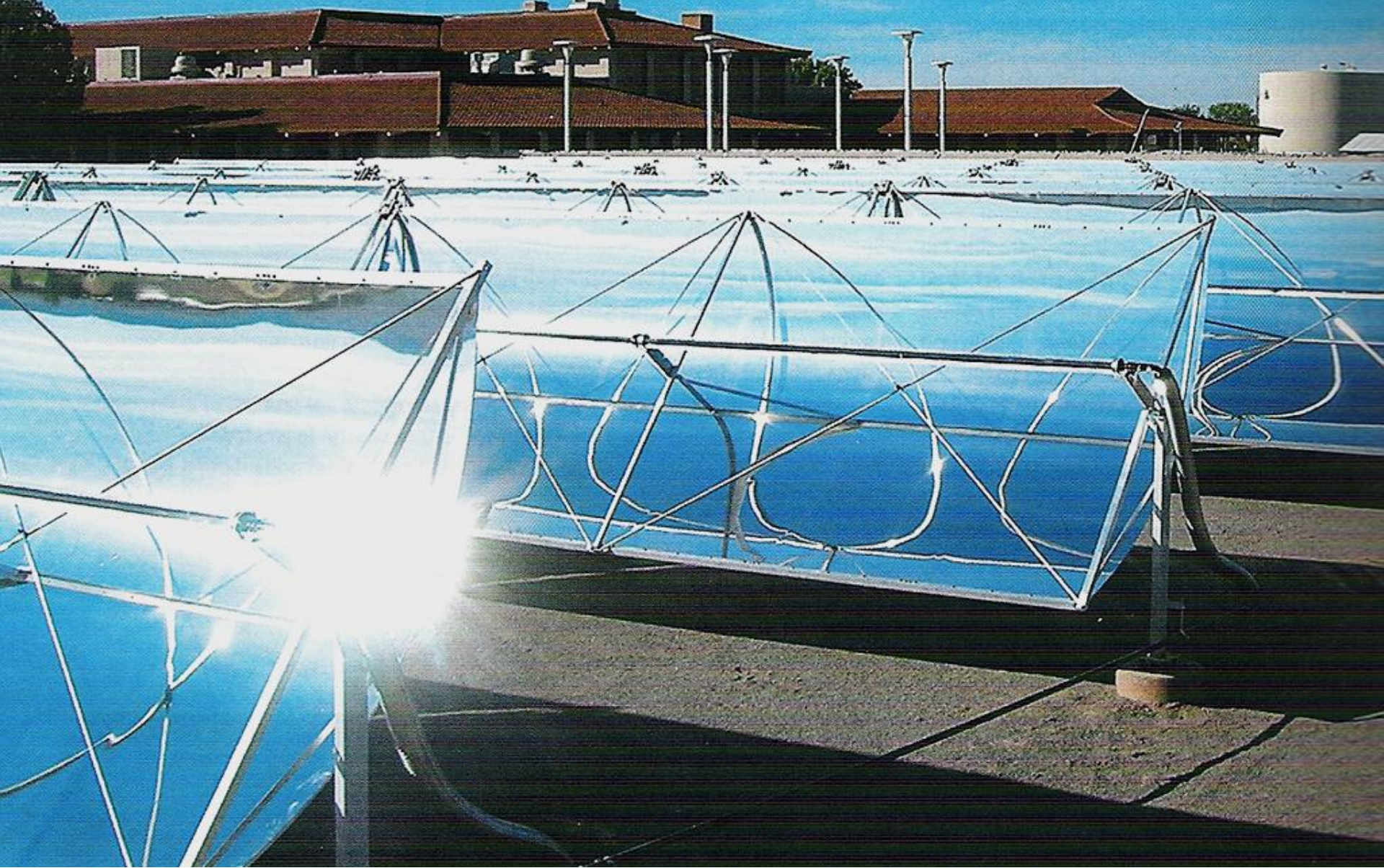

Concentrating solar thermal systems for roof integration



solar tower

Photovoltaic effect and silicon cells

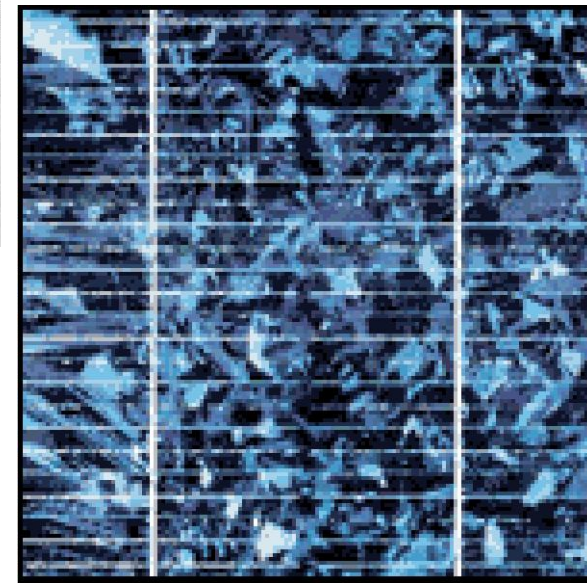
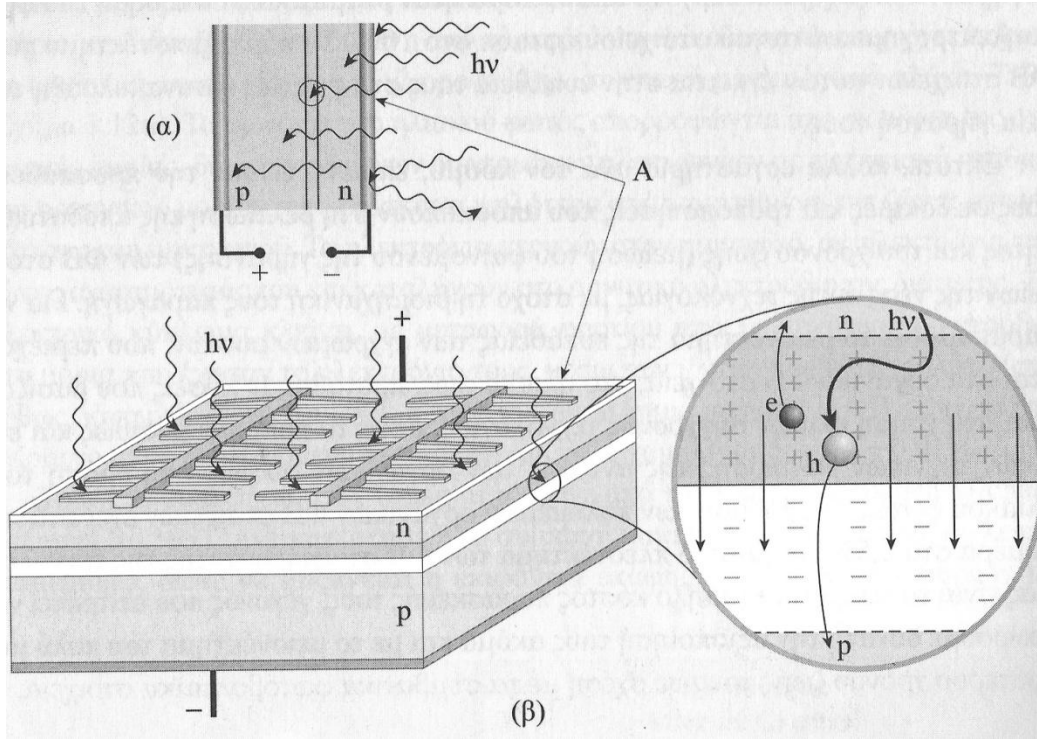

Photons are absorbed by the semiconducting material of solar cells, resulting to the production of voltage/current



Photovoltaics

Greece: 600 MW - Europe: 50.000 MW - World 67.500 MW

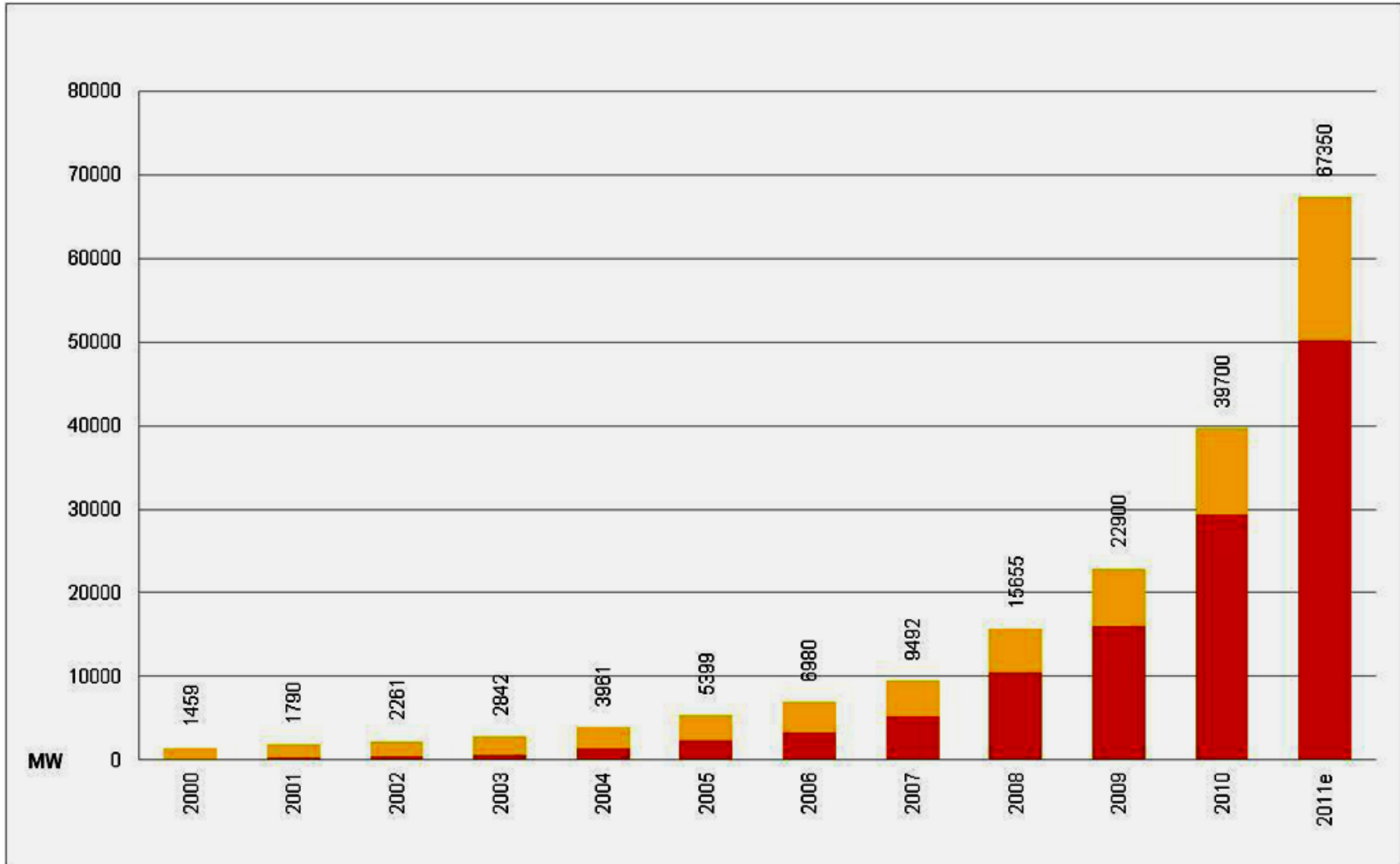



Photovoltaics

Photovoltaic park







Photovoltaics

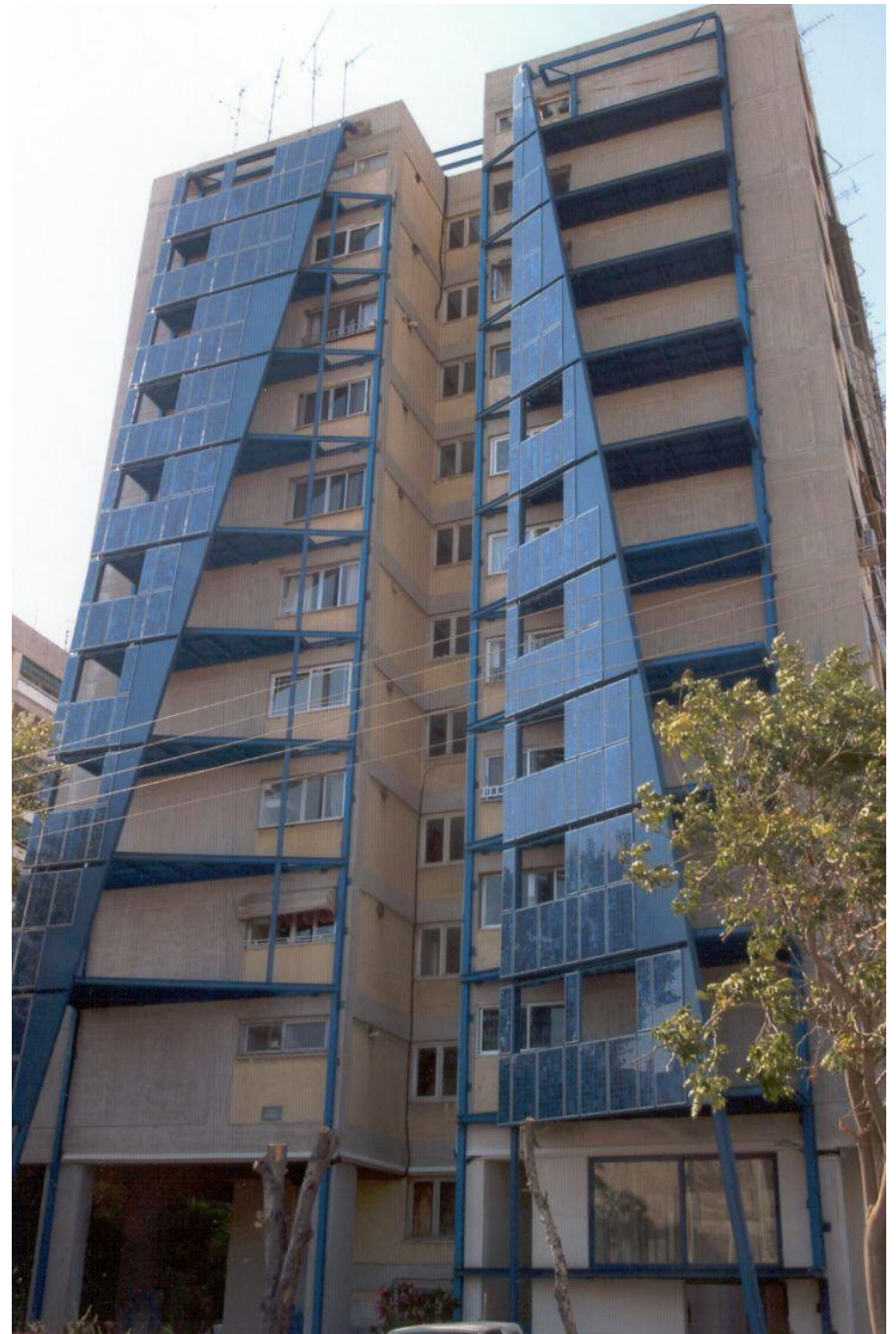



Photovoltaics
for Semi-
transparent
building
façades

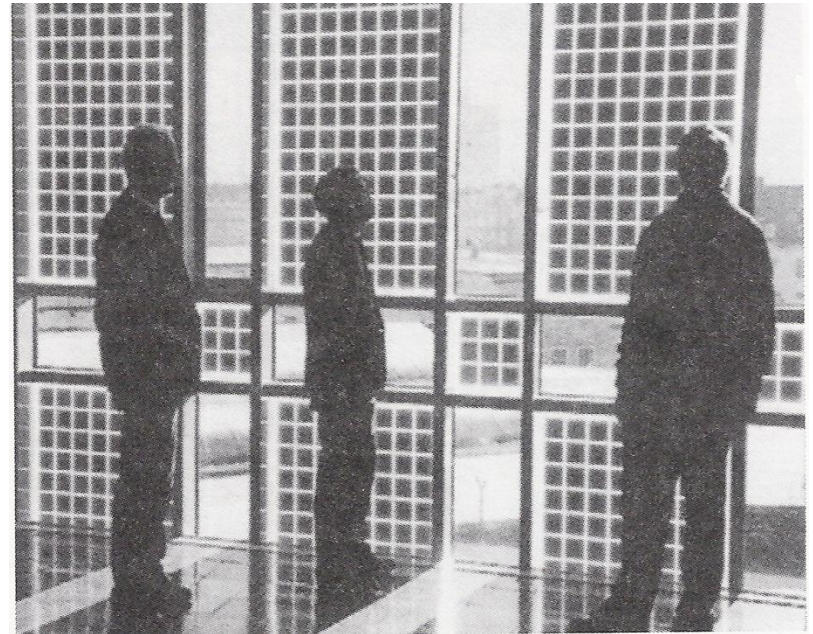

Hybrid Photovoltaic/Thermal solar systems

The hybrid Photovoltaic/Thermal (PV/T) solar collectors are consisted of mounted together photovoltaic panels and thermal units that extract the heat and provide simultaneously electricity and heat.

Thermal collectors and Photovoltaics separately installed on building roof



Concept of Hybrid Photovoltaic/Thermal solar systems



Photovoltaics convert 5%-15% (depending on the technology) of the solar radiation into electricity and the rest is converted into heat.



The heat increases the temperature of PV modules and this results to electrical efficiency drop.



This effect can be partially avoided by applying a suitable heat extraction mode



The PV modules combined with thermal units consist the hybrid Photovoltaic/Thermal (PV/T) systems providing electrical and thermal output.



PV/T systems provide simultaneously electricity (5%-15%) and heat (50%-70%).

Hybrid Photovoltaic/Thermal Solar Energy Systems

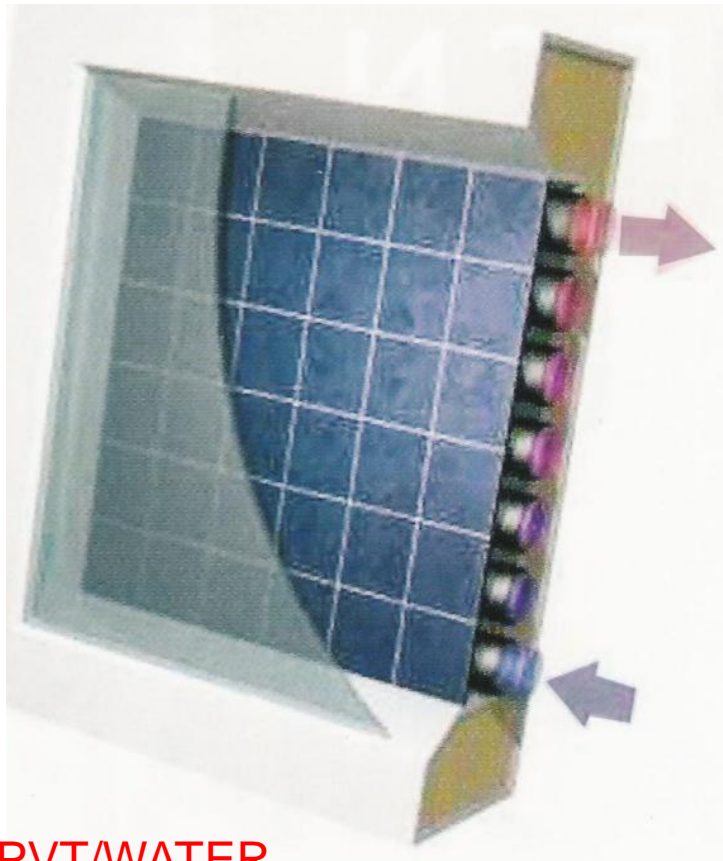
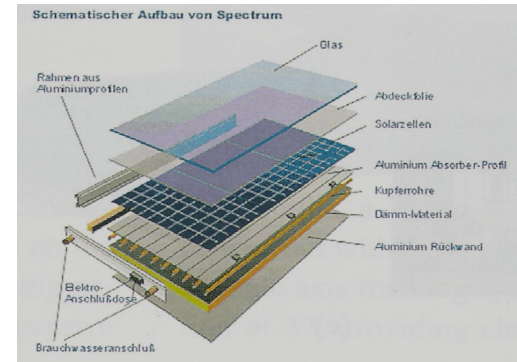

PVT/WATER

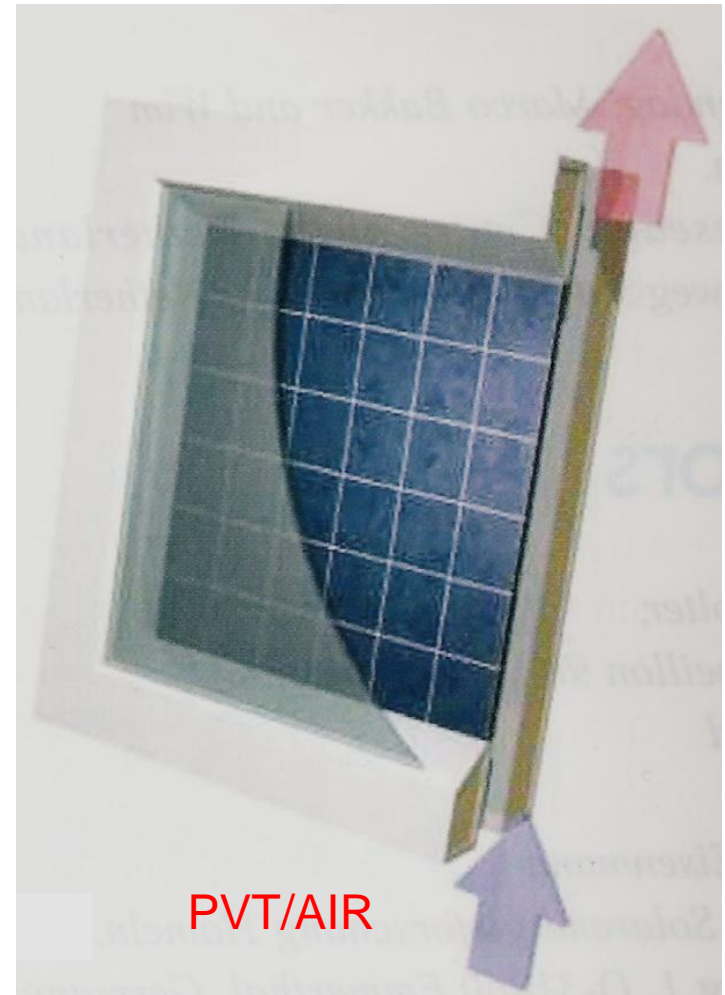

PVT/AIR

Schematischer Aufbau von Spectrum

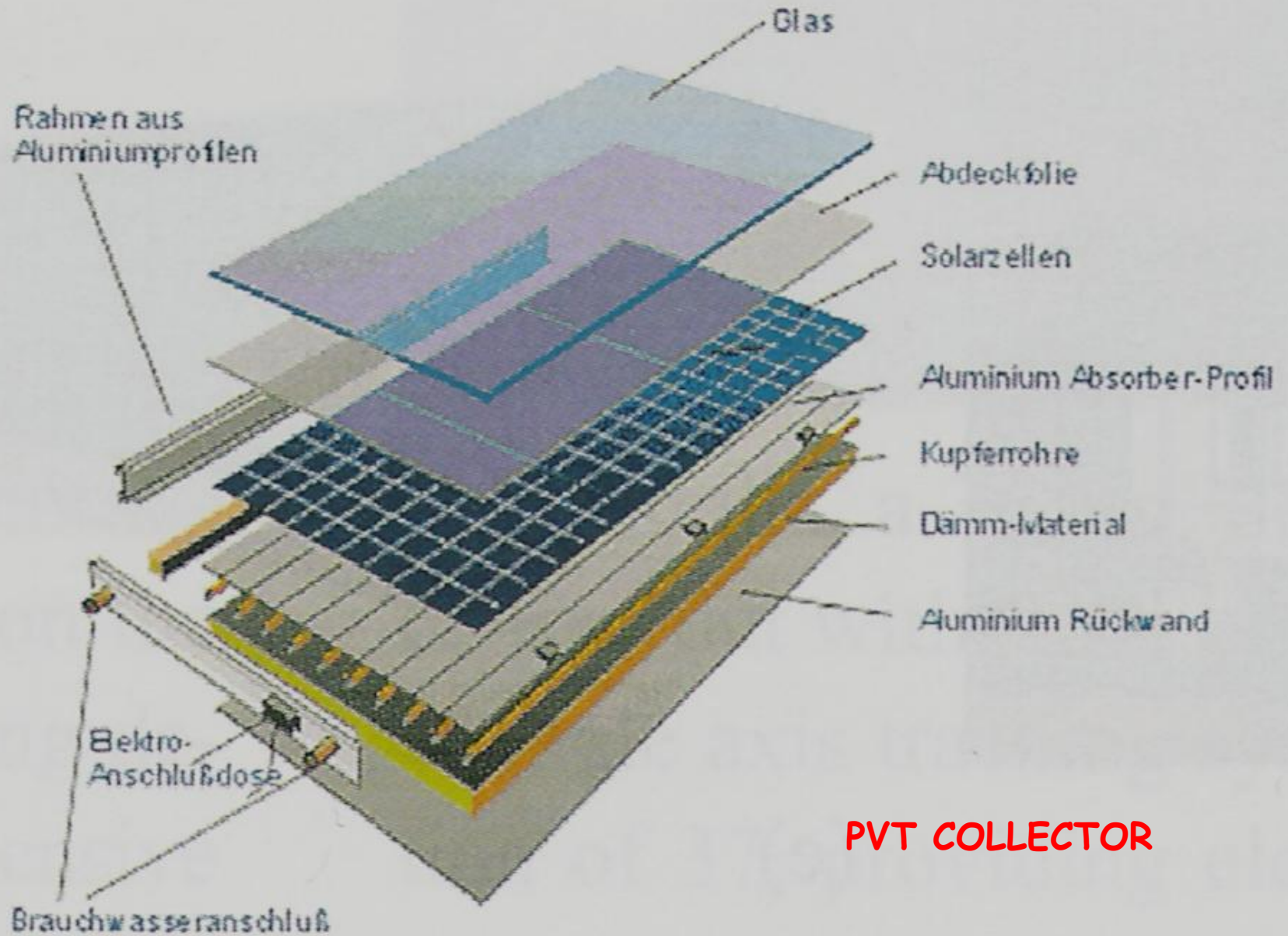

PVT COLLECTOR

Hybrid Photovoltaic/Thermal Solar Energy Systems

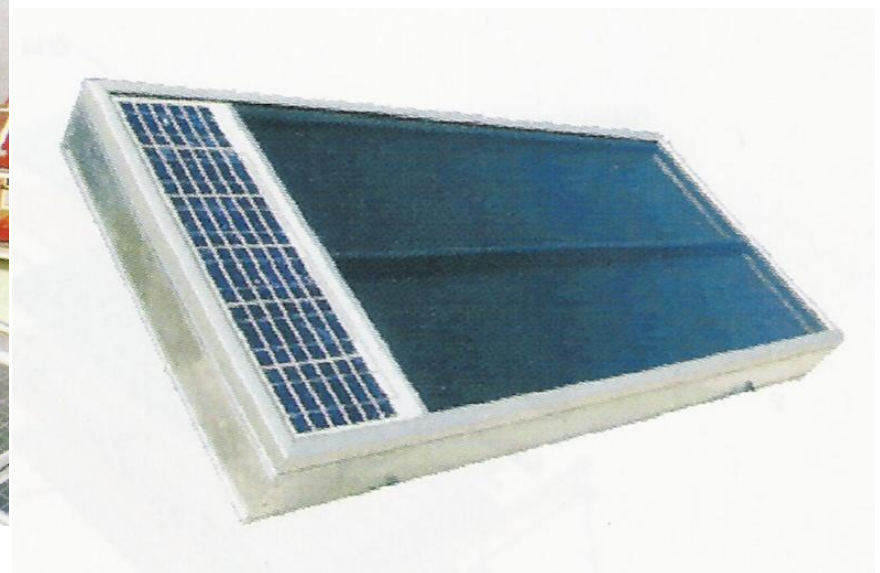

Hybrid Photovoltaic/Thermal Solar Energy Systems installed on buildings



Aspects for Hybrid Photovoltaic/Thermal systems



Air-cooled PV modules (PVT/AIR systems) can cover building heating and ventilation needs.



Water-cooled PV modules (PVT/WATER systems) are used for water heating, space heating, etc.



PV/T solar collectors integrated on buildings can replace the thermal collectors and photovoltaics



In PV/T collectors the electrical and thermal efficiencies depend on PV temperature

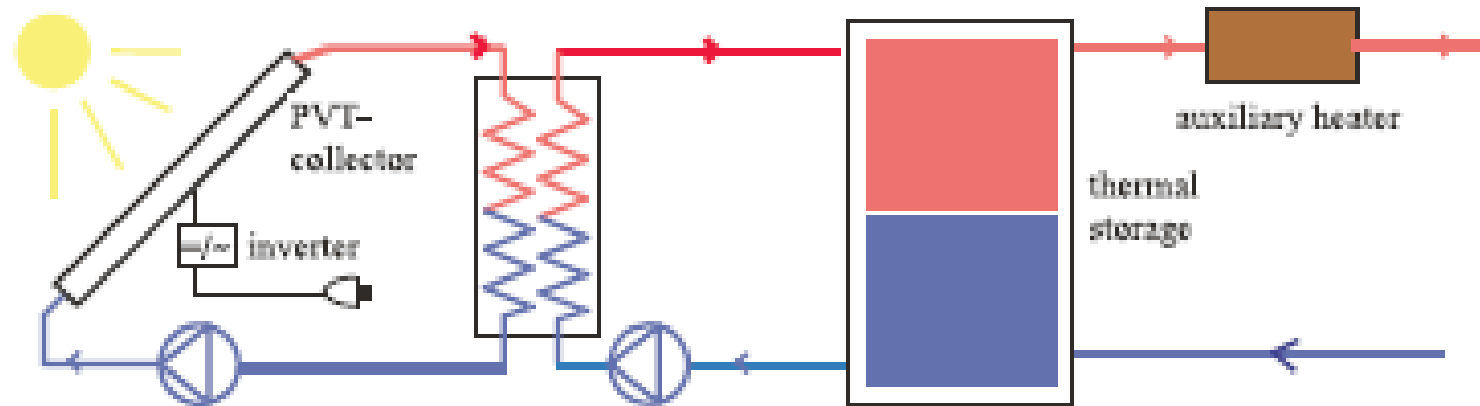

type of hot water demand

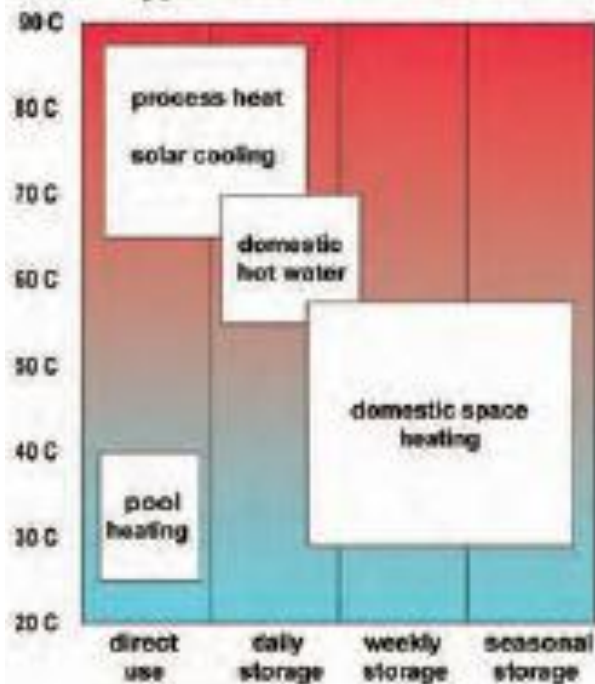

type of hot air demand

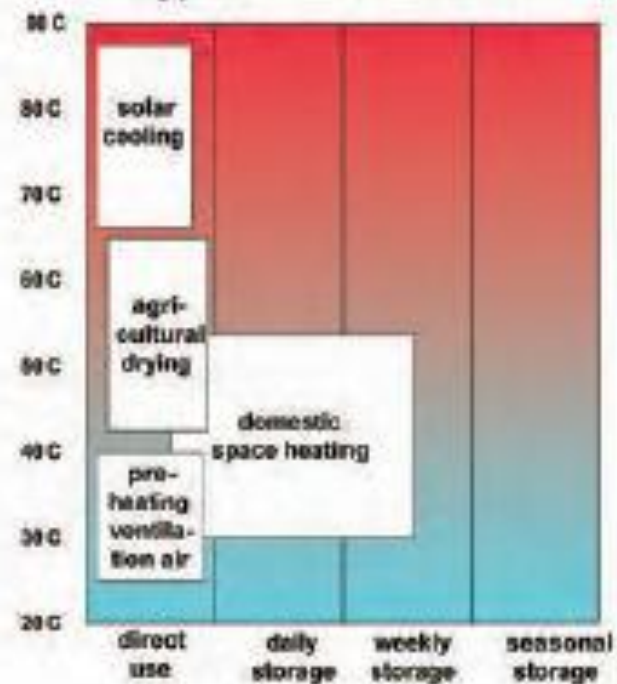

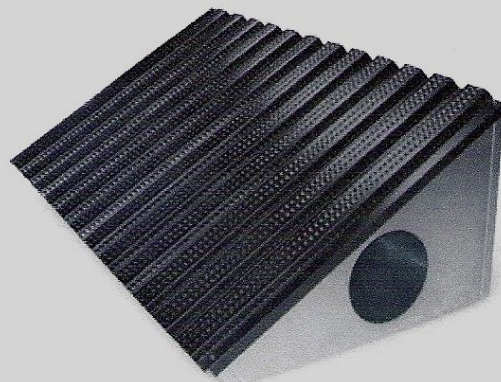
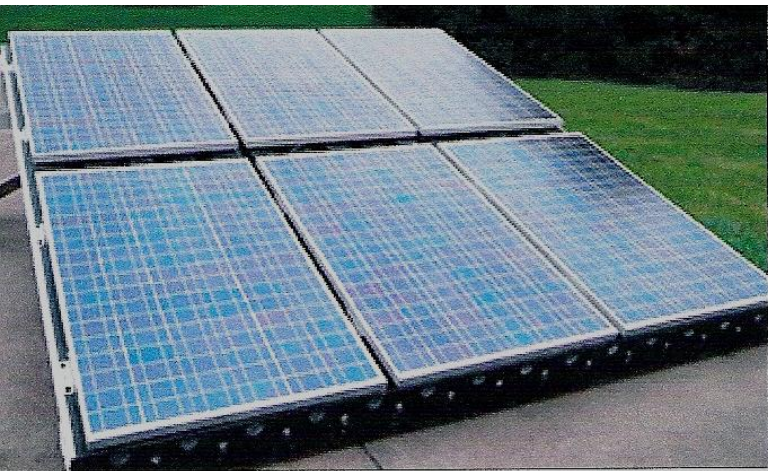

Solar Wall PVT collector



- 1 SolarDuct™ System
- 2 Air Handling Units (AHU)
- 3 Hot Air Ducts

This roadmap was developed as part of the EU-supported Coordination Action PV-Catapult

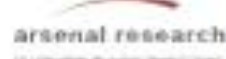
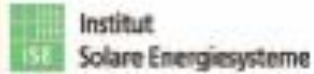

Arontis CPVT collector



Photo: Arontis - Jordan Dijkster

Heliodynamics Fresnel reflector PV/T collector



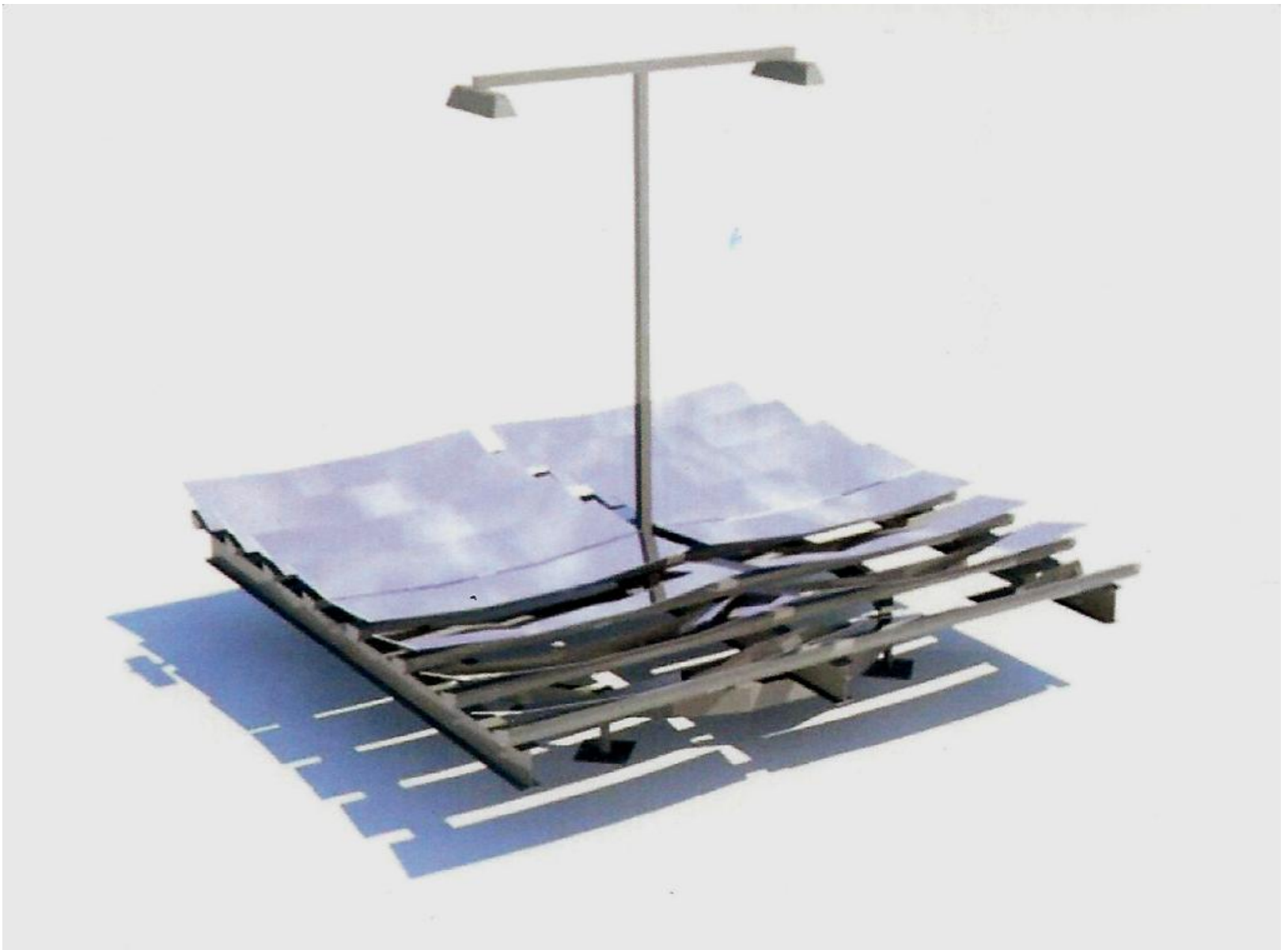

Hybrid Photovoltaic/Thermal solar collectors with Fresnel reflectors (Menova system)

UPatras developed PV/T collectors

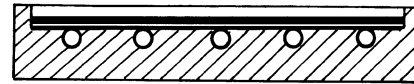
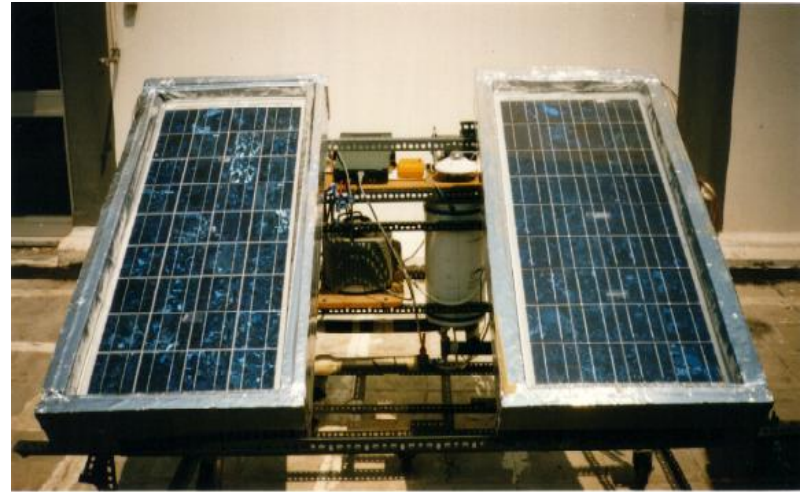

a PV / WATER

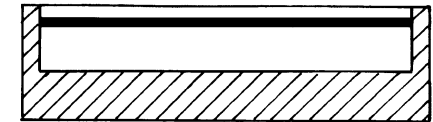

c PV / AIR

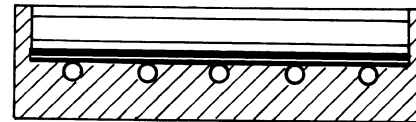

b PV / WATER + GL



d PV / AIR + GL

CROSS SECTION OF STUDIED PV/T SYSTEMS

Diffuse reflectors between the parallel rows of the installed PV/T collectors on horizontal roof.

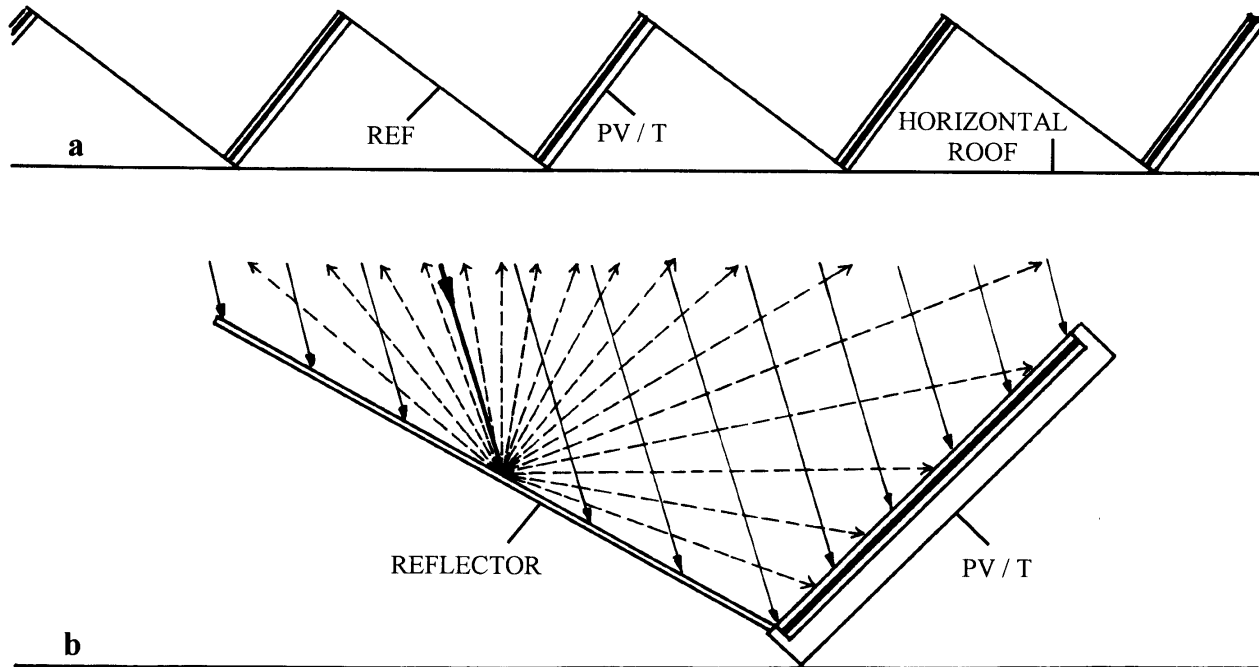

A performance improvement can be achieved by using diffuse reflectors between the parallel rows of the installed PV/T collectors on horizontal roof.

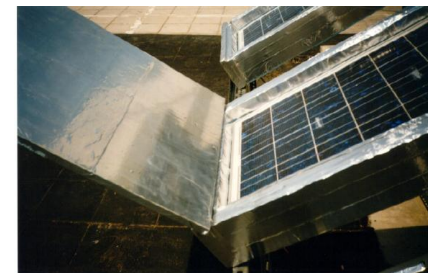

Electrical efficiency for pc-Si PV/T + REF hybrid solar energy systems

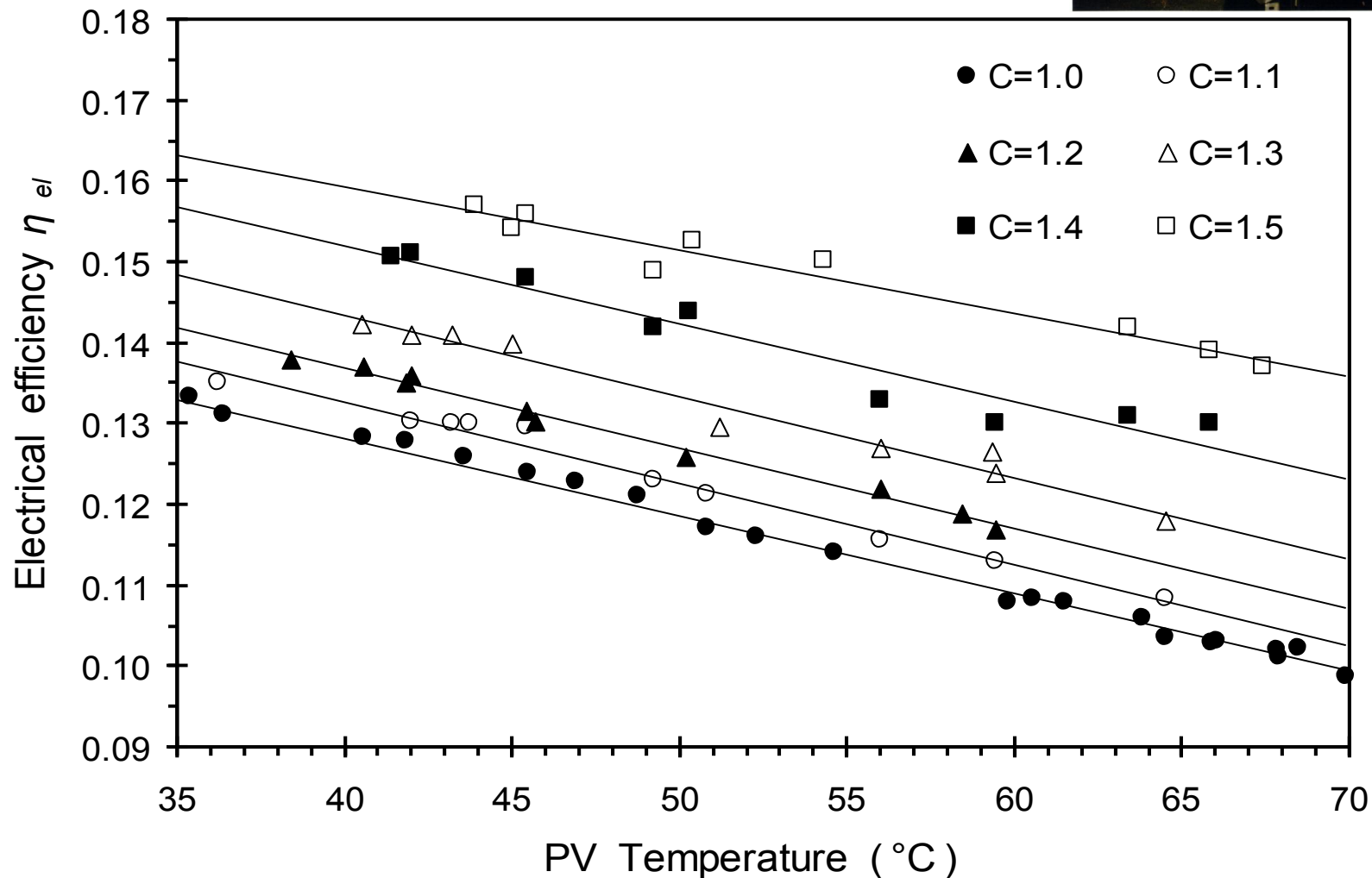
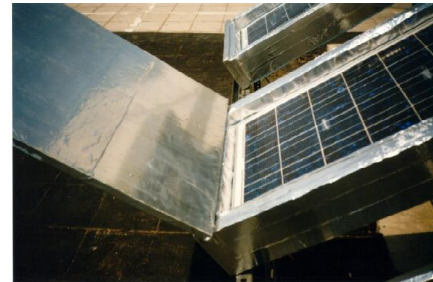

Test results of Thermal efficiency for pc-Si PV/T water system

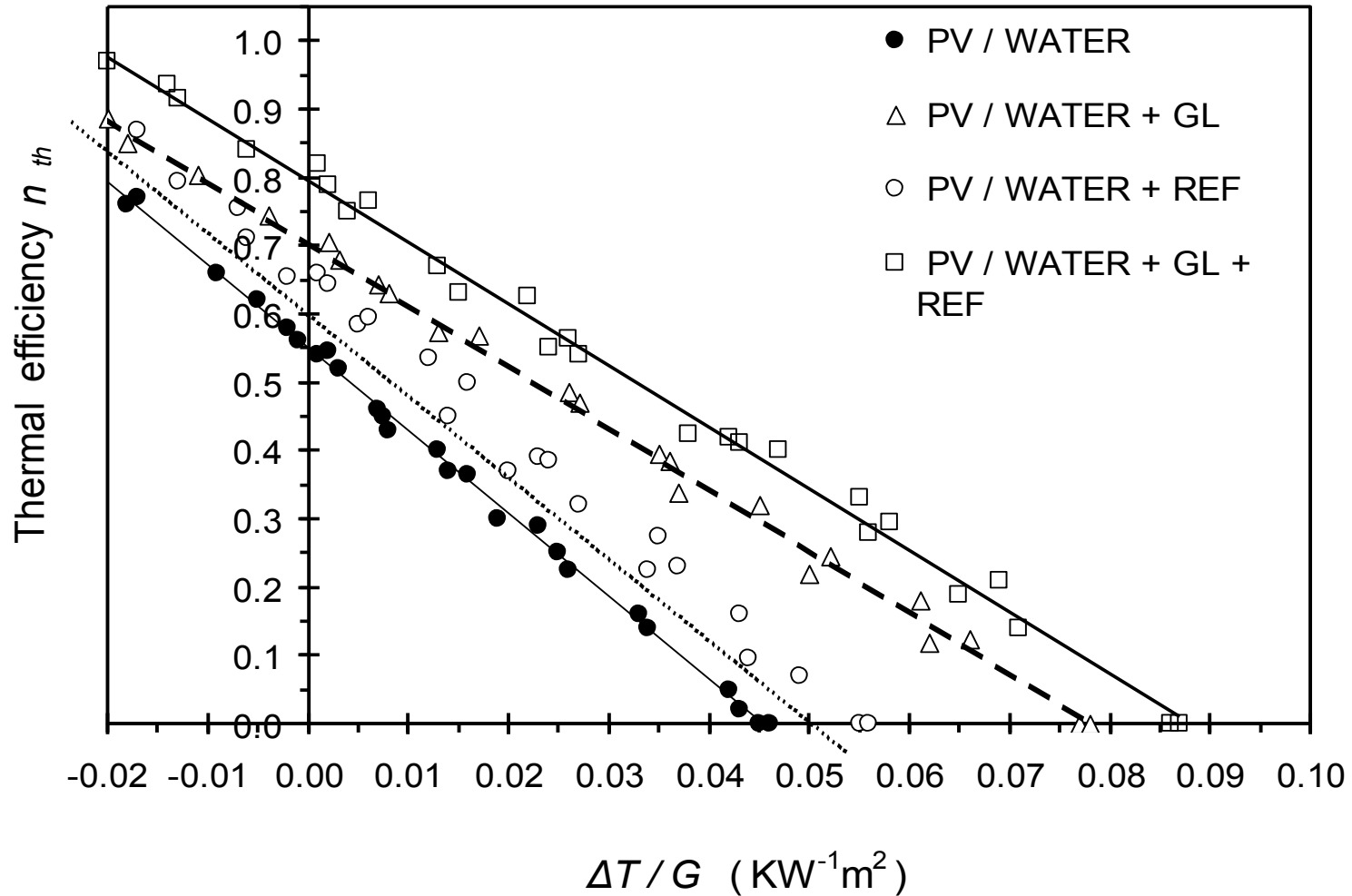

Test results of Thermal efficiency for pc-Si PV/T air system

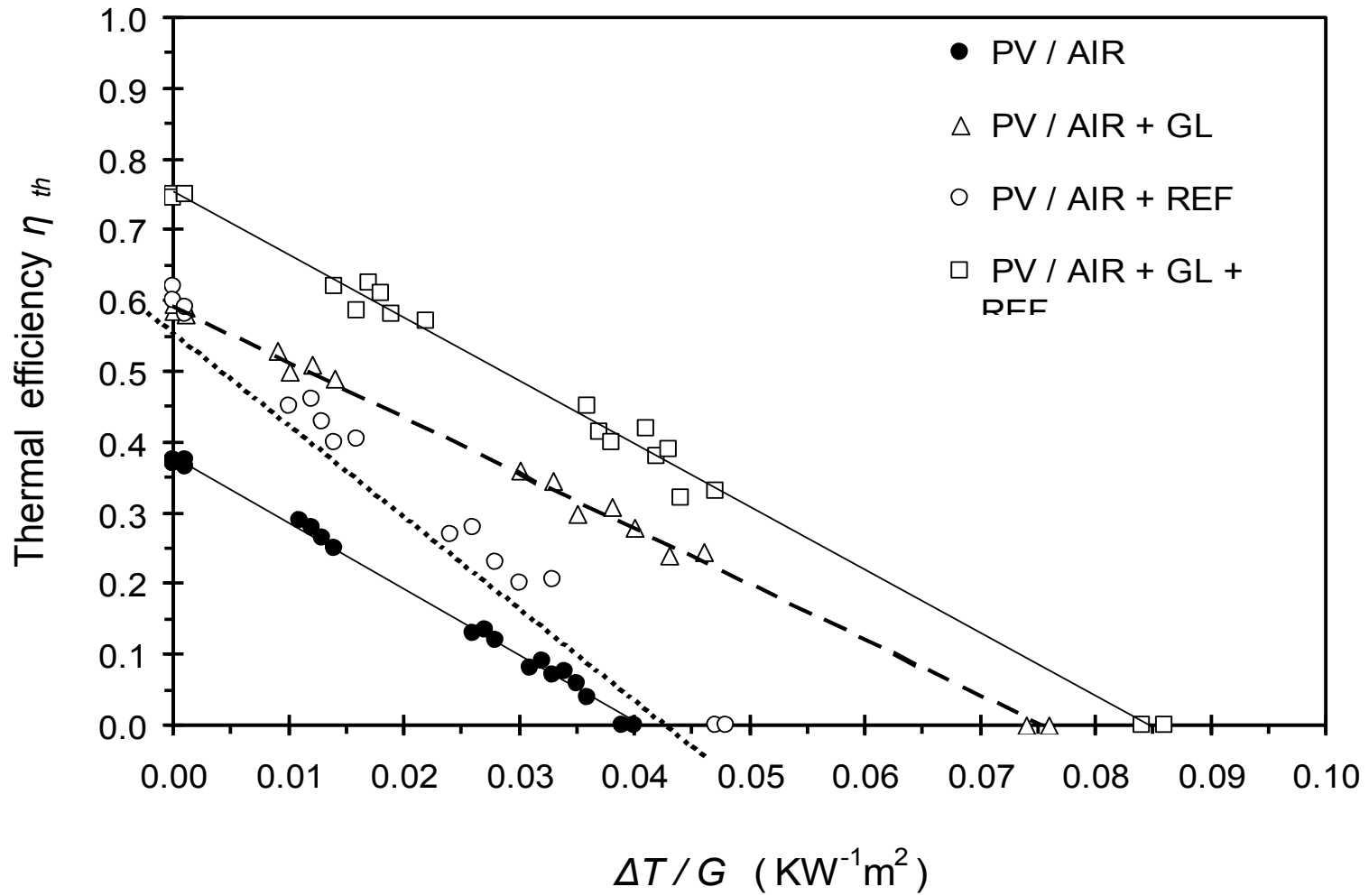

Test results of electrical efficiency for pc-Si PV/T water system

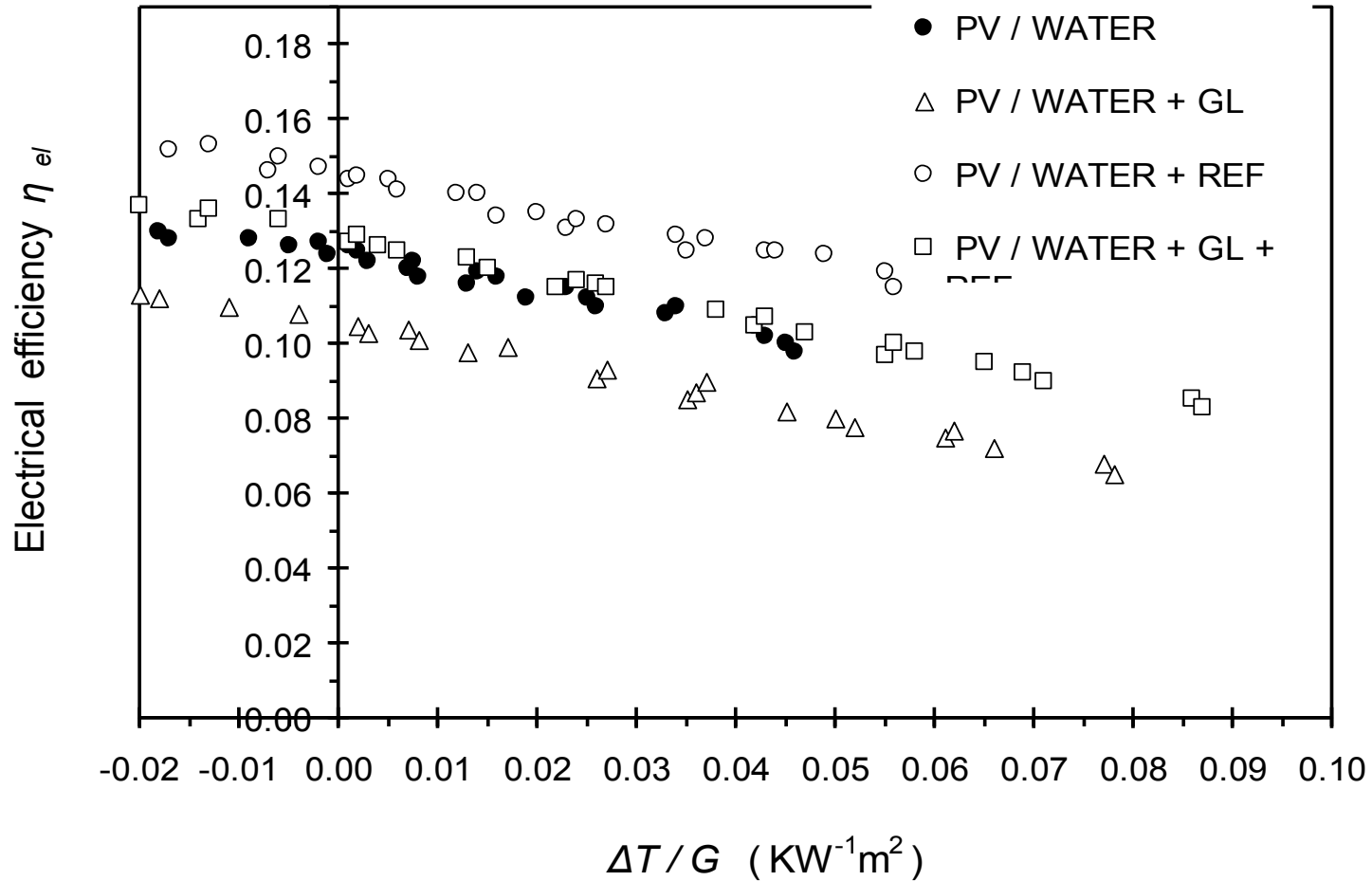

Test results of electrical efficiency for pc-Si PV/T air system

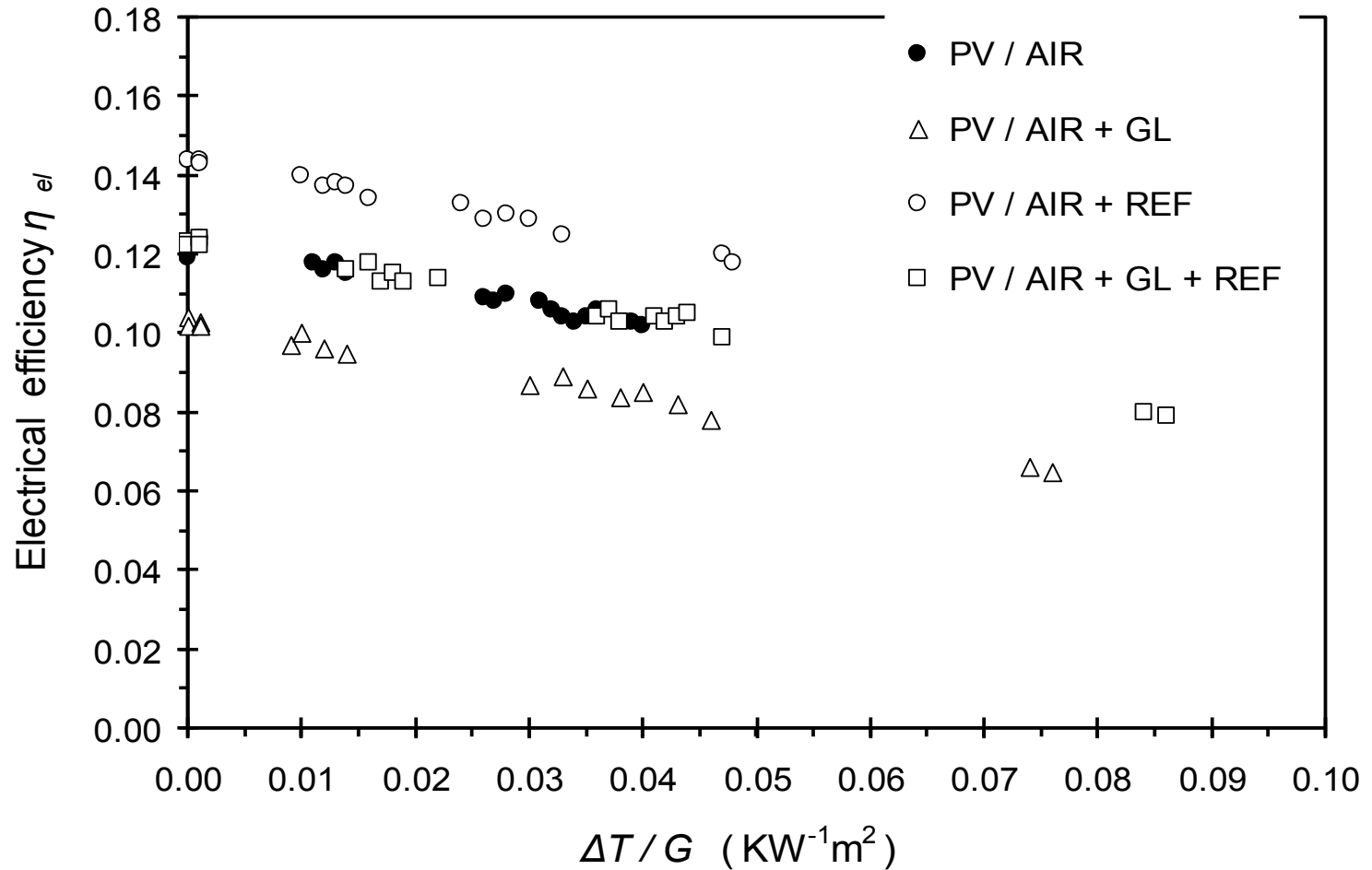

TMS air heat exchanger

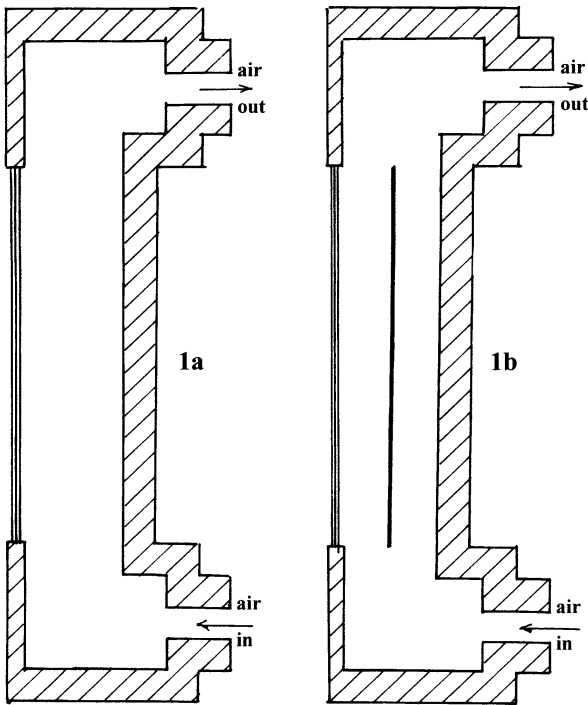

We increase the heat exchanging surface area inside the air channel by using a thin flat metallic sheet (TMS) suspended in the middle of the cavity to improve air heat extraction and prevent building overheating

Hybrid Photovoltaic/Thermal solar systems with air heat extraction

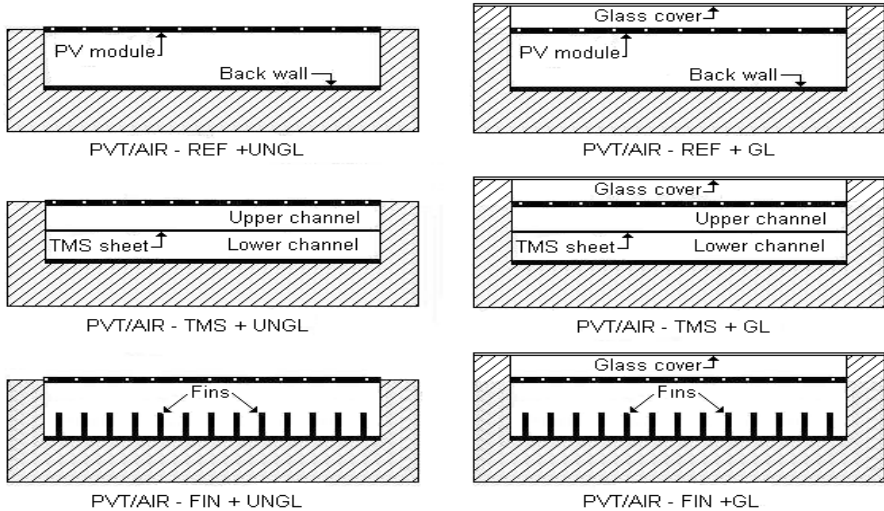

PV/T with air heat extraction
 PV/T of glazed and unglazed type
 PV/T systems with improvements

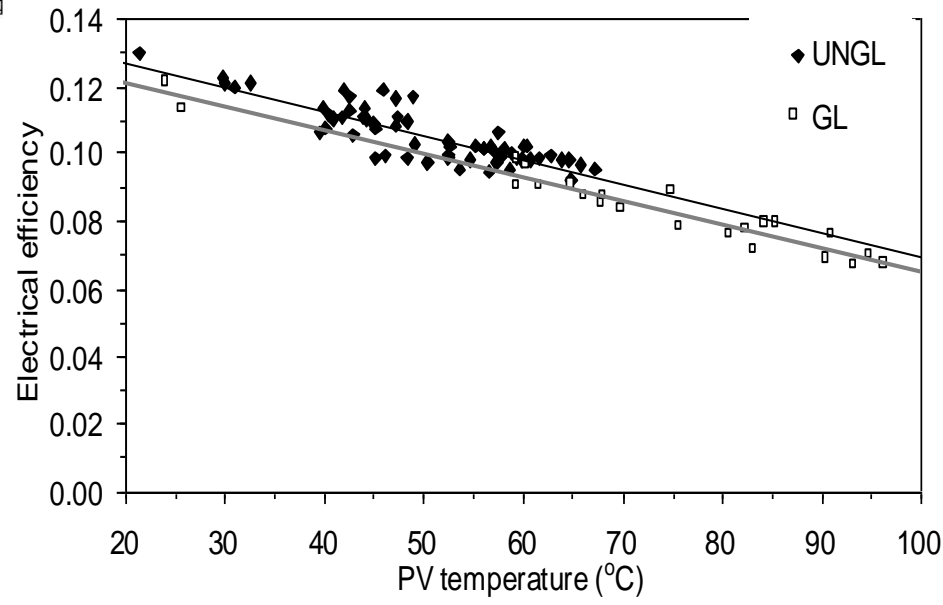
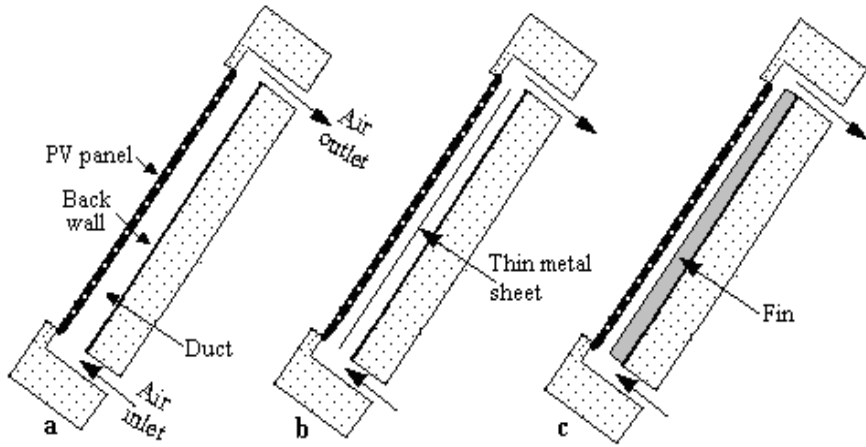

The PVT/DUAL system concept

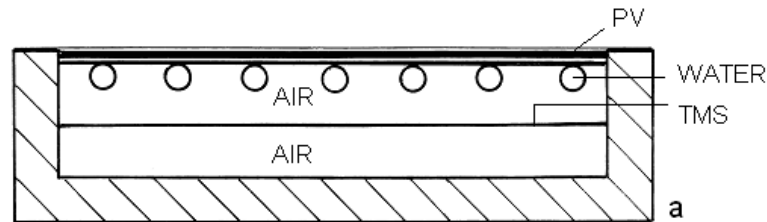

TMS

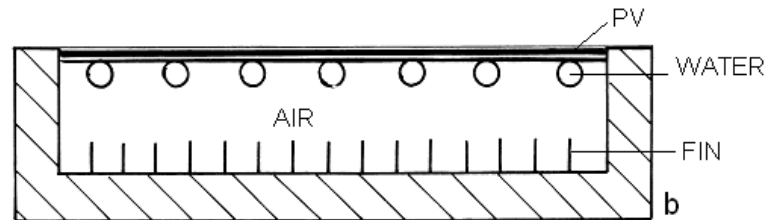

FIN

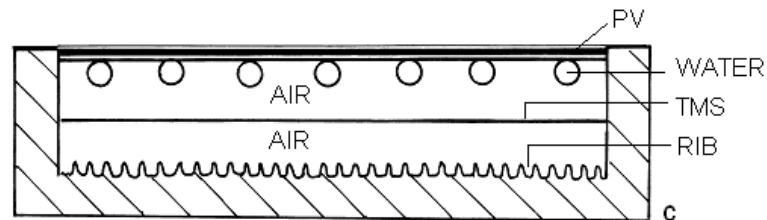

TMS/RIB

This system can operate either with **water** or with **air** heat extraction, according to the weather conditions and the energy demand of the building

PVT/AIR façade integration

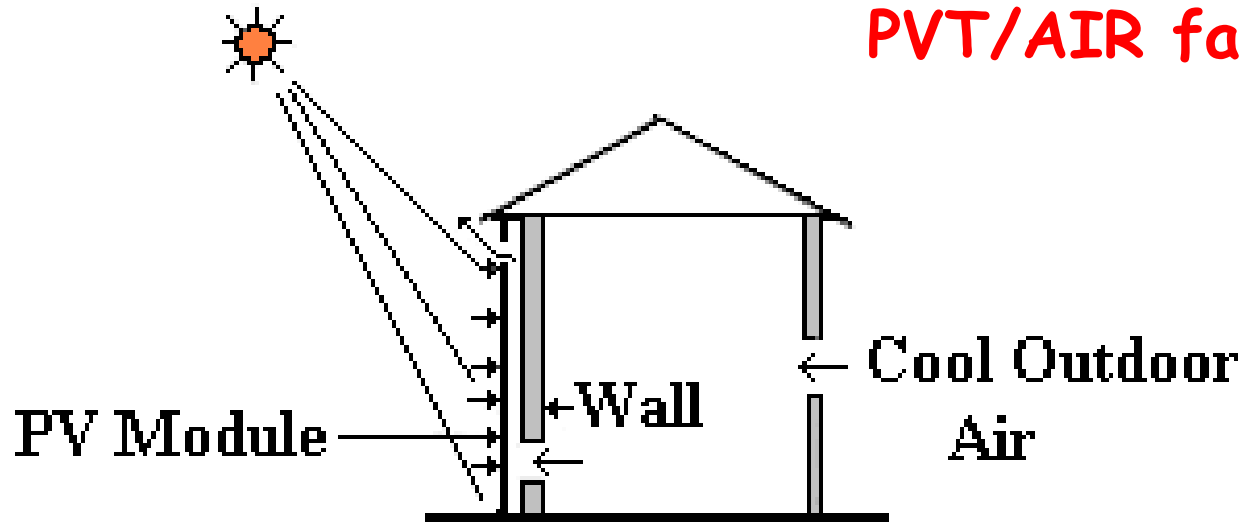

PV mounted on Façade for Ventilation

PV modules integrated on the façade with air gap contribute to a heat flow of circulating air out of the building.

Fresh air enters into the building through open windows and doors or infiltration and achieve natural ventilation.

PVT/AIR Roof integration

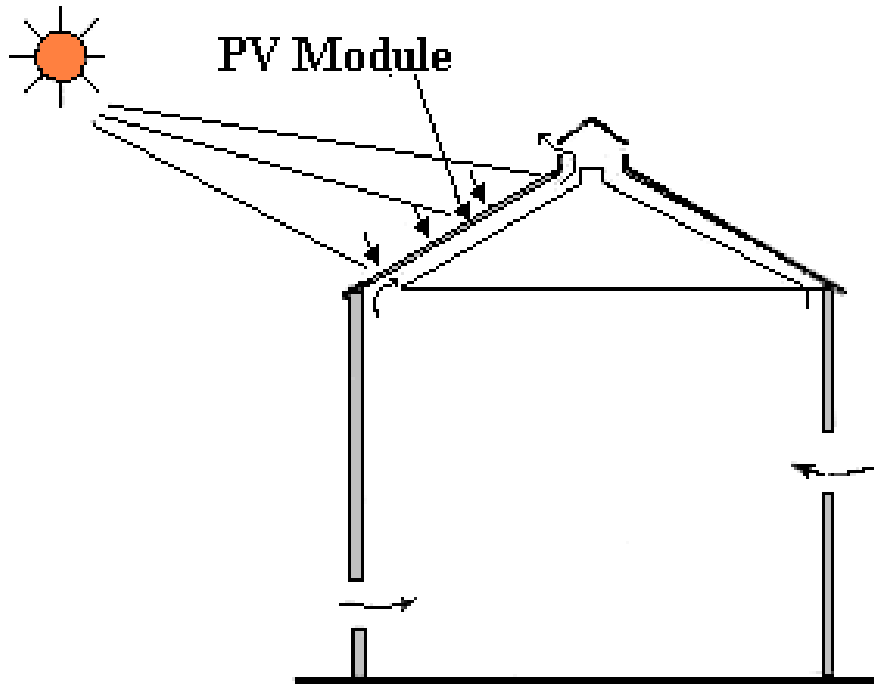

**PV module mounted
as a Solar Roof Ventilator**

PV module mounted on the roof operates as a roof solar collector.

Fresh air enters into building through open (or infiltration) windows and doors and achieves natural ventilation.

PV/T system can be used as "ventilation driver" for natural ventilation of building creating substantial ventilation rate with air velocity about 1 ms^{-1} .

TMS "shields" the back wall up to about 3°C below that of REF system and reduces building heat load in summer.

Energy Pay Back Time results

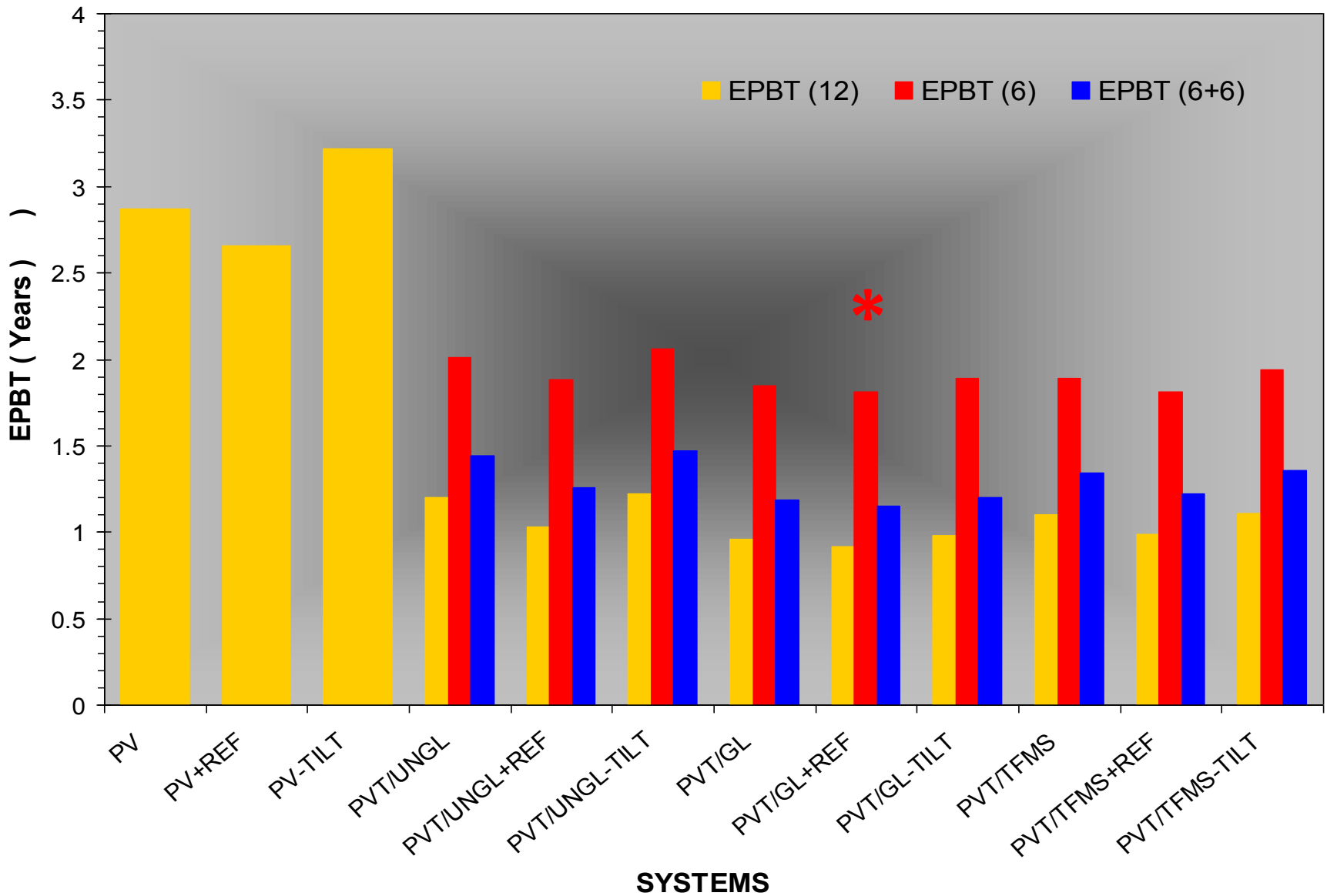

Thermosiphonic PVT/WATER collectors



Multi Solar System, MSS Millenium
Electric, Israel

HYBRID PHOTOVOLTAIC/THERMAL SOLAR SYSTEMS

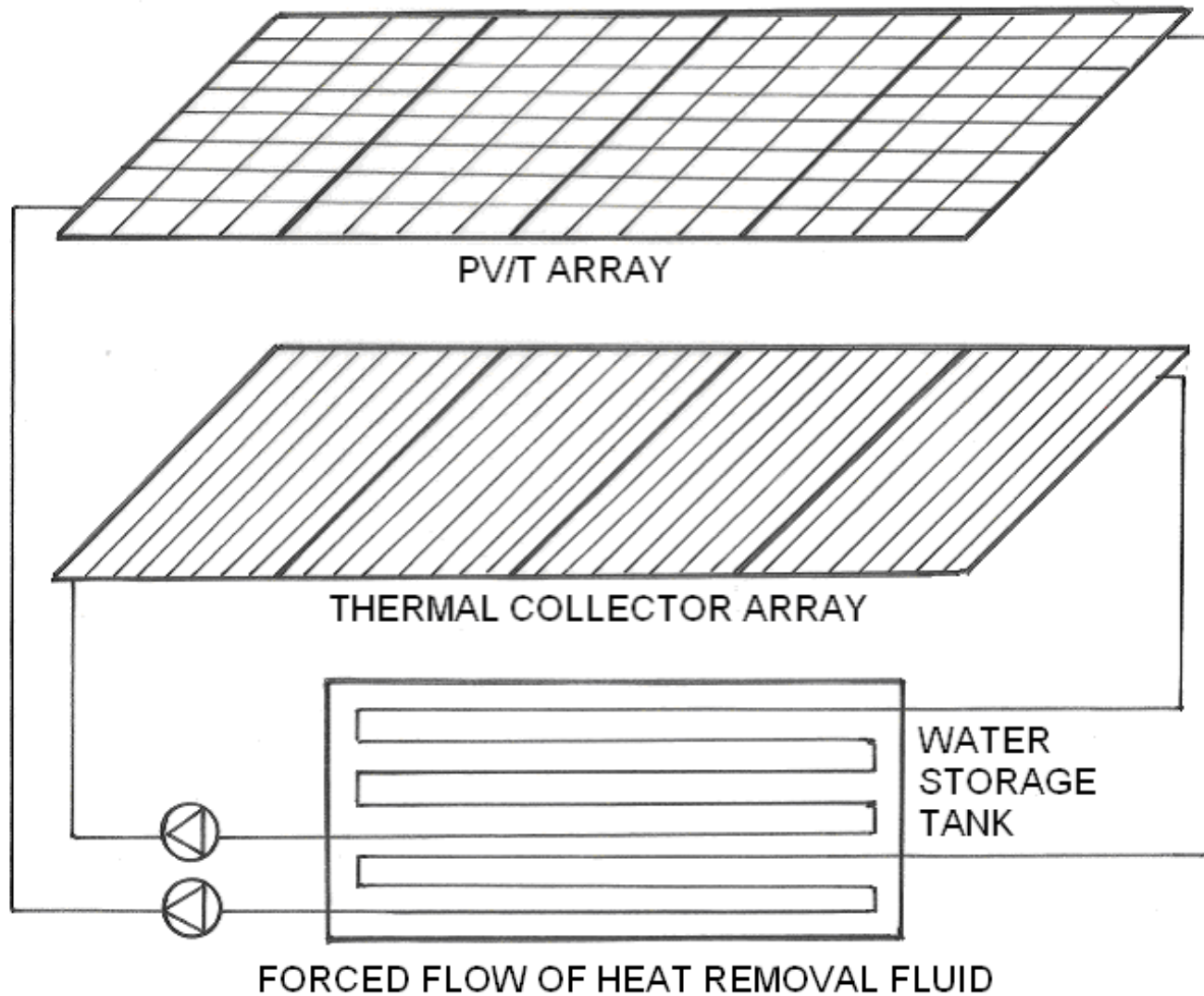

Improved performance with separated thermal collector and PV/T system

PV/T systems combined with Fresnel lenses

The direct incident solar radiation can be concentrated on an absorber strip, located at the focal position and can be taken away to achieve lower illumination level and also to avoid the overheating of the space.

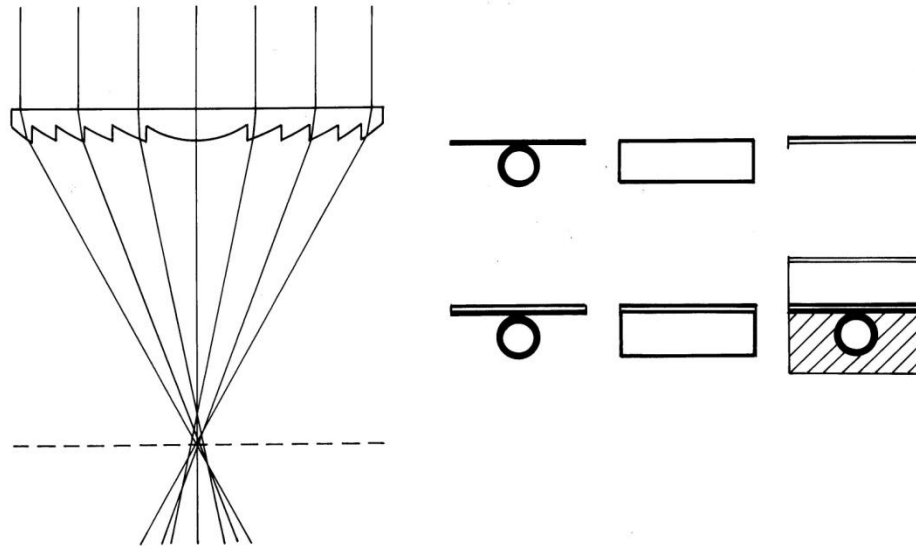

In low intensity irradiance, the absorber can be out of focus leaving the light to come in the interior space and keep the illumination at an acceptable level.



The operation concept of the fresnel lenses with tracking absorbers

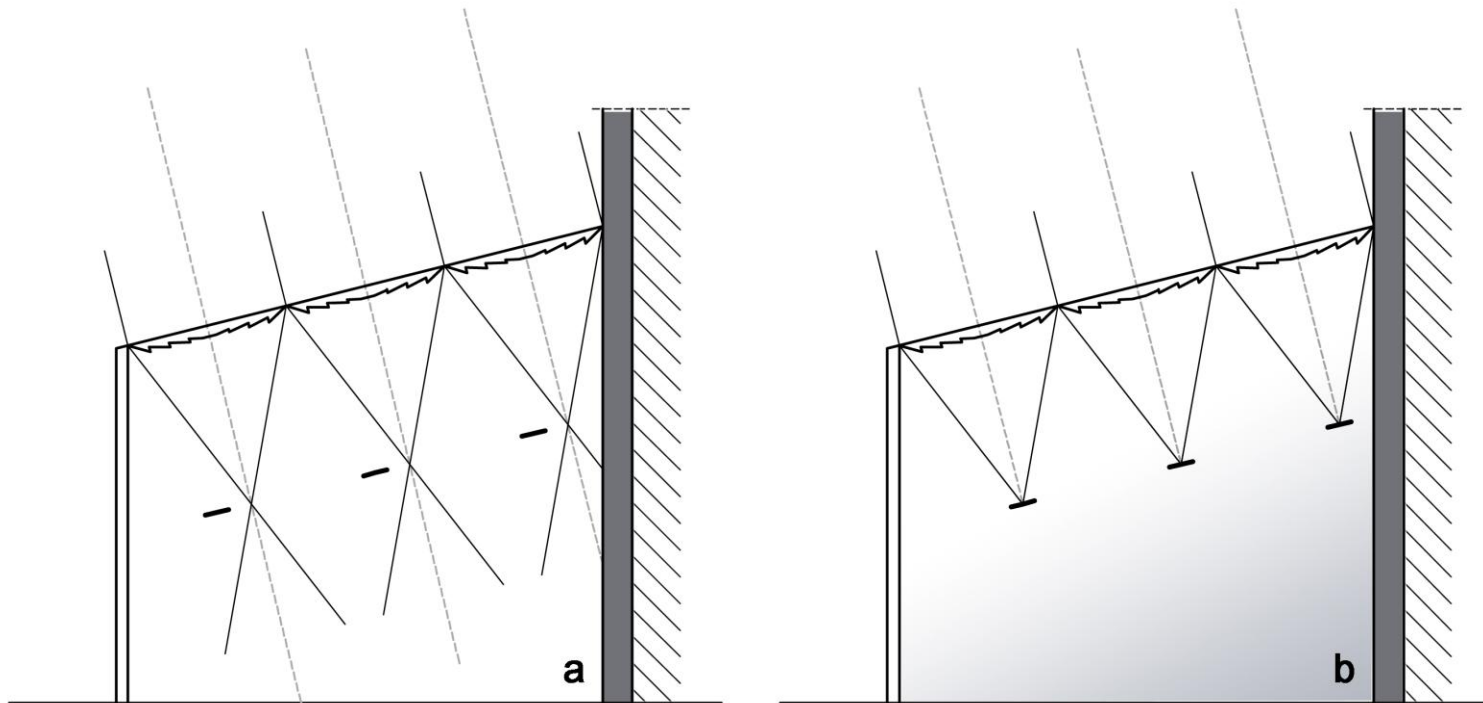

Absorbers out of focus

Absorbers at focus

To control the illumination and the temperature of the transparently covered internal spaces of buildings (atria, sunspaces) the tracking absorbers play a significant role.

Application of fresnel lenses in buildings

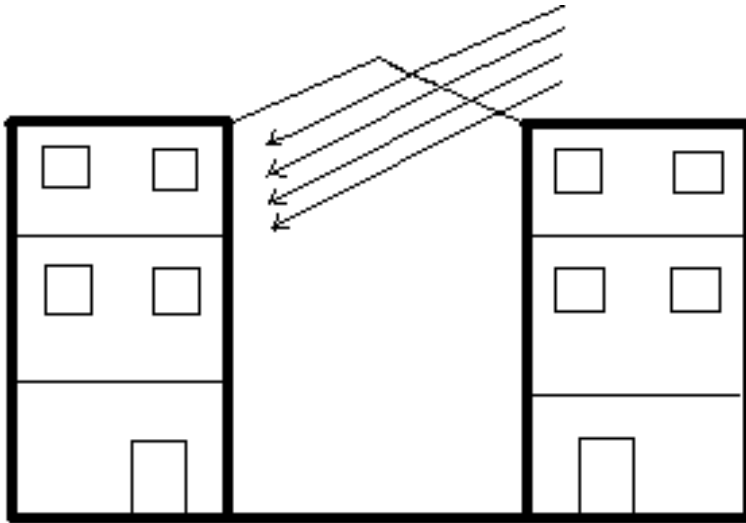

atrium

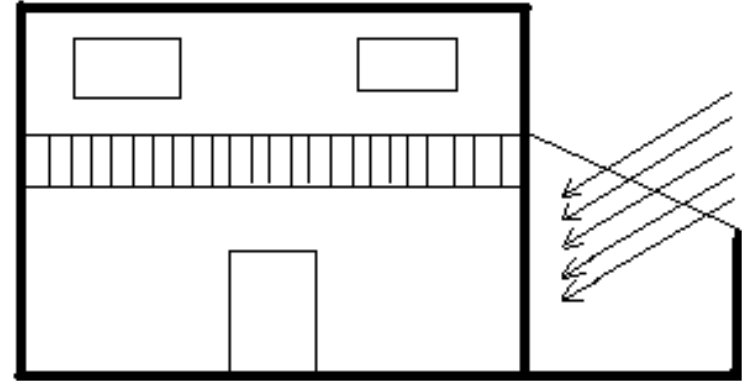

sunspace



room



industry

CPC reflectors combined with linear PV and PVT absorbers

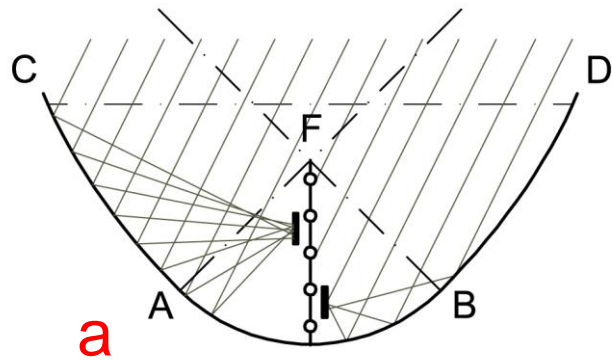

Stationary CPC reflectors with flat bifacial absorber (a) can be combined with PV strips that track the converged solar radiation and absorb the concentrated solar radiation.

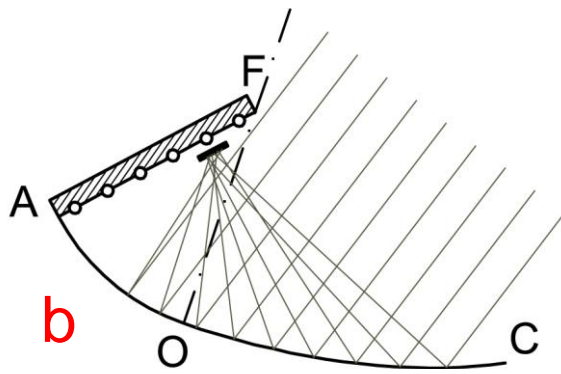

The non-absorbed beam solar radiation and the diffuse solar radiation are absorbed by the flat bifacial thermal absorber and can be taken away by the circulation of a heat removal fluid.

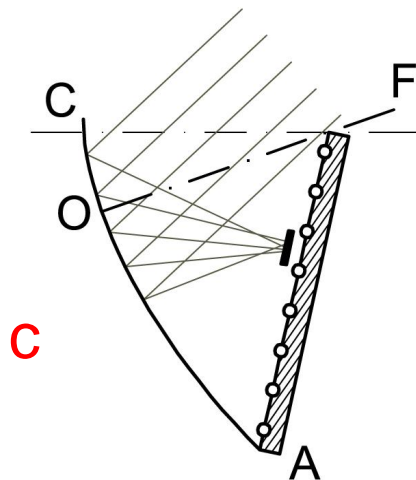

In asymmetric CPC reflector, the PV strip is moving in front of the thermal absorber, tracking the converged solar radiation.

The parabola axis is directed to:
(b) the higher altitude of sun (summer) or to
(c) the lower sun altitude (winter).



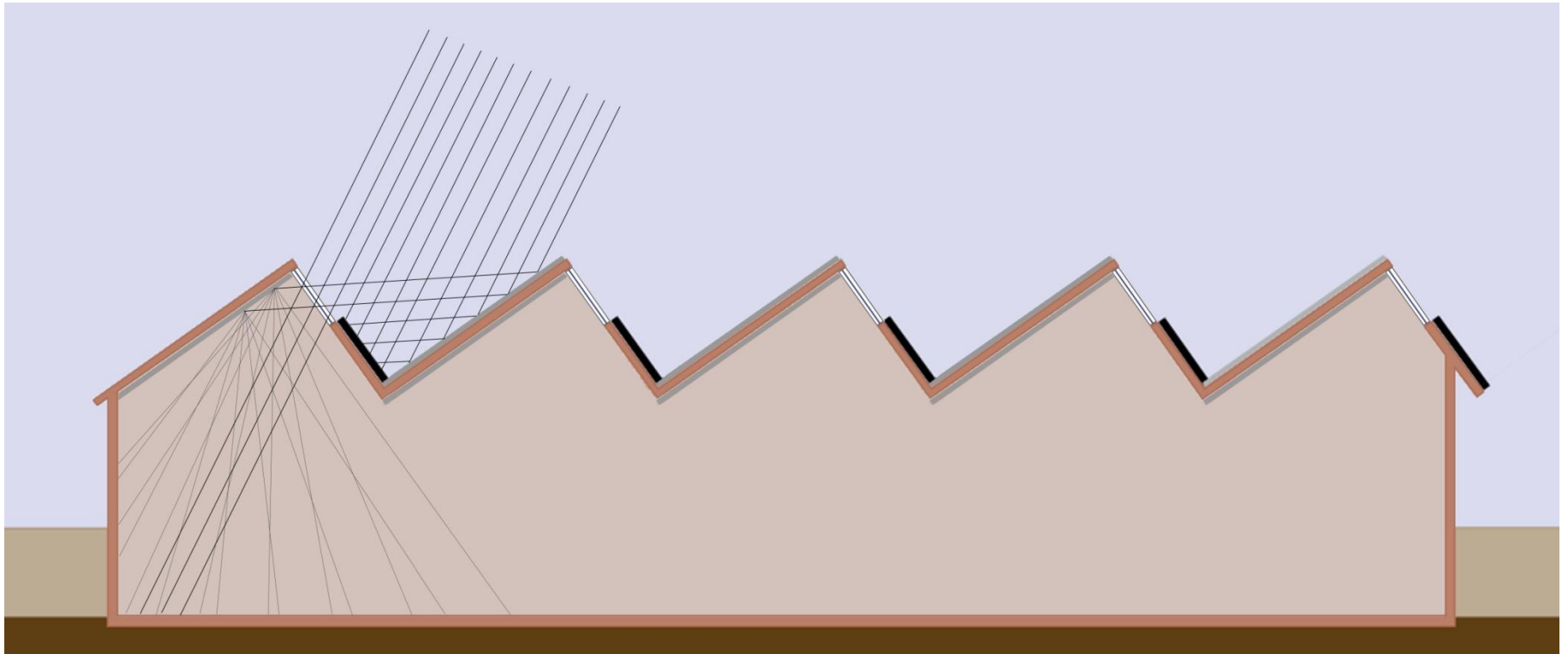

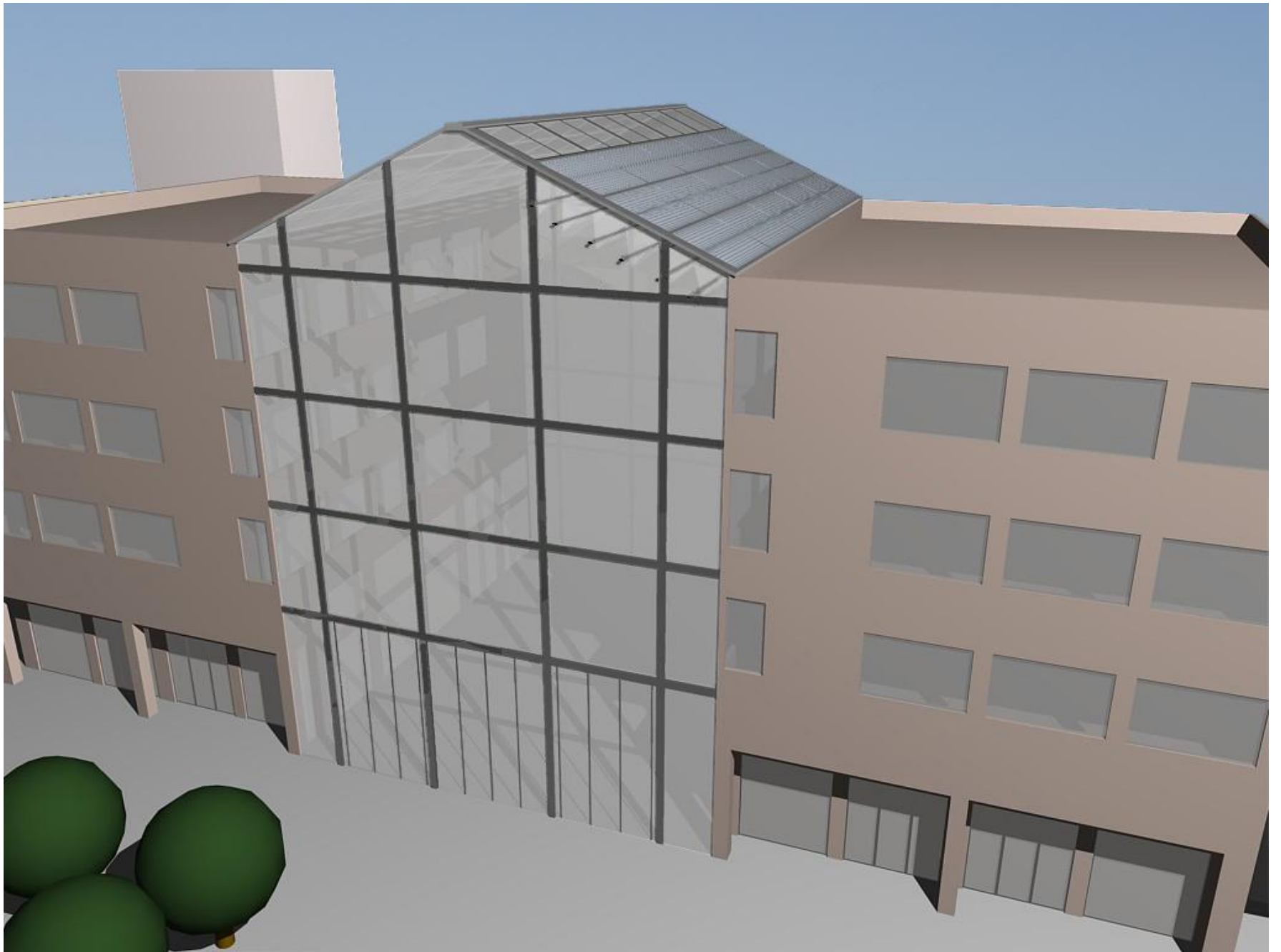

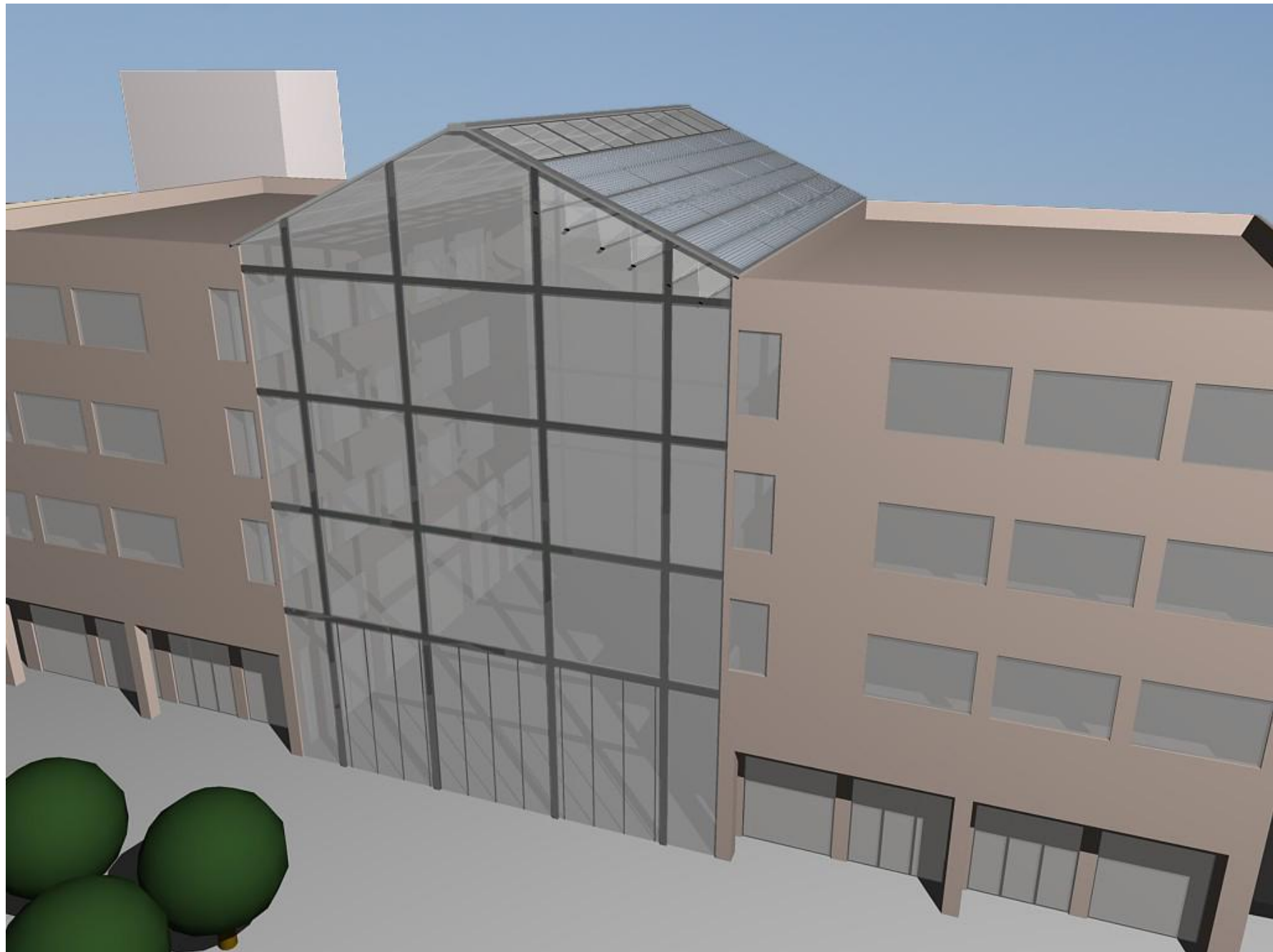

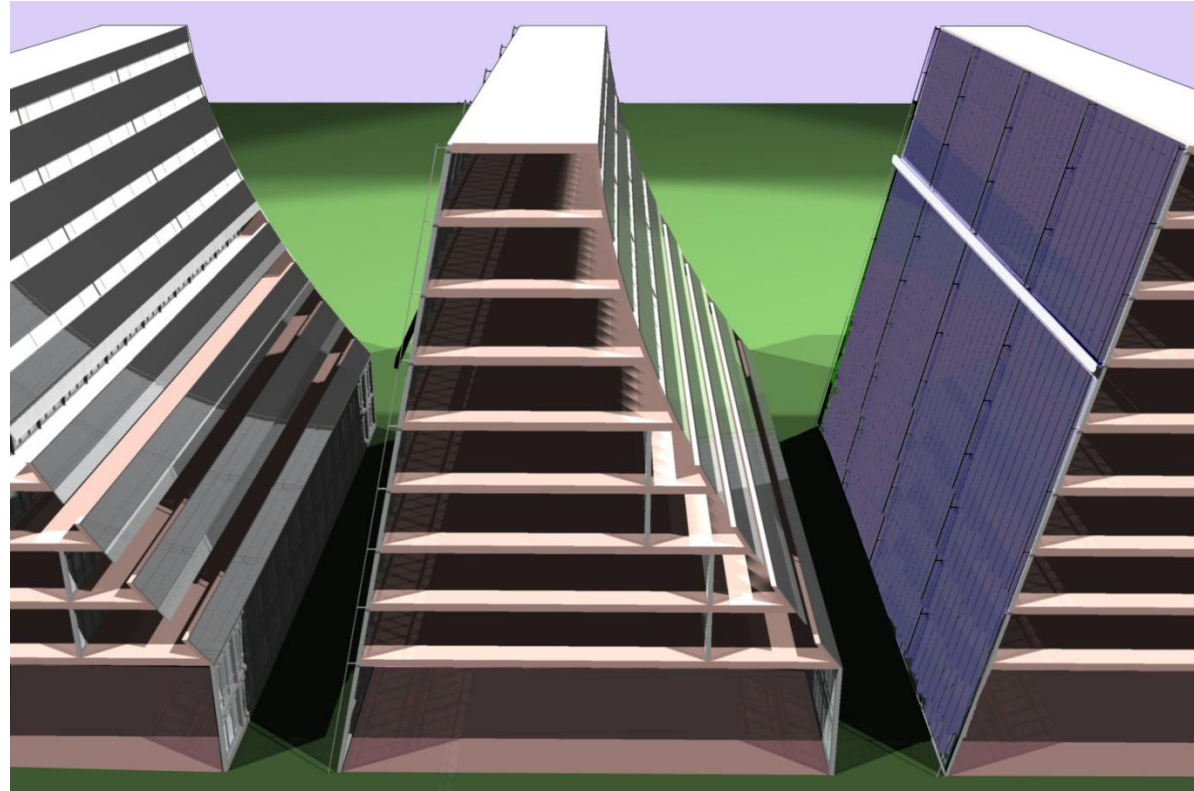
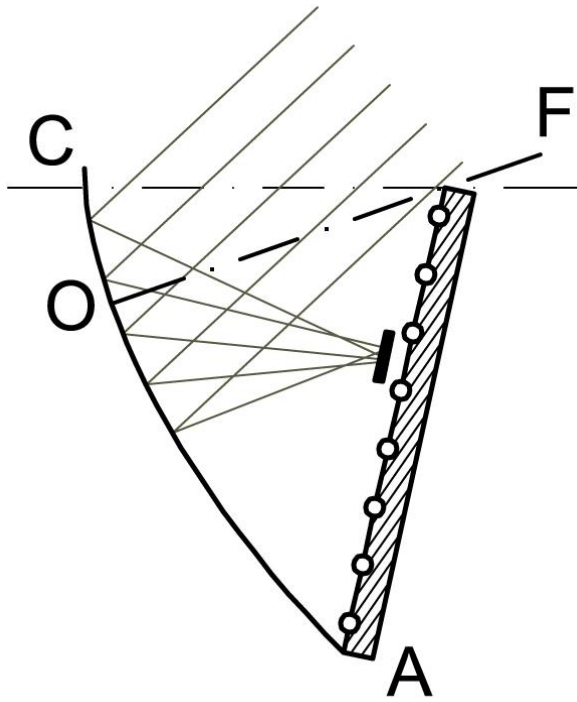

Architectural design of CPC-PVT building integration

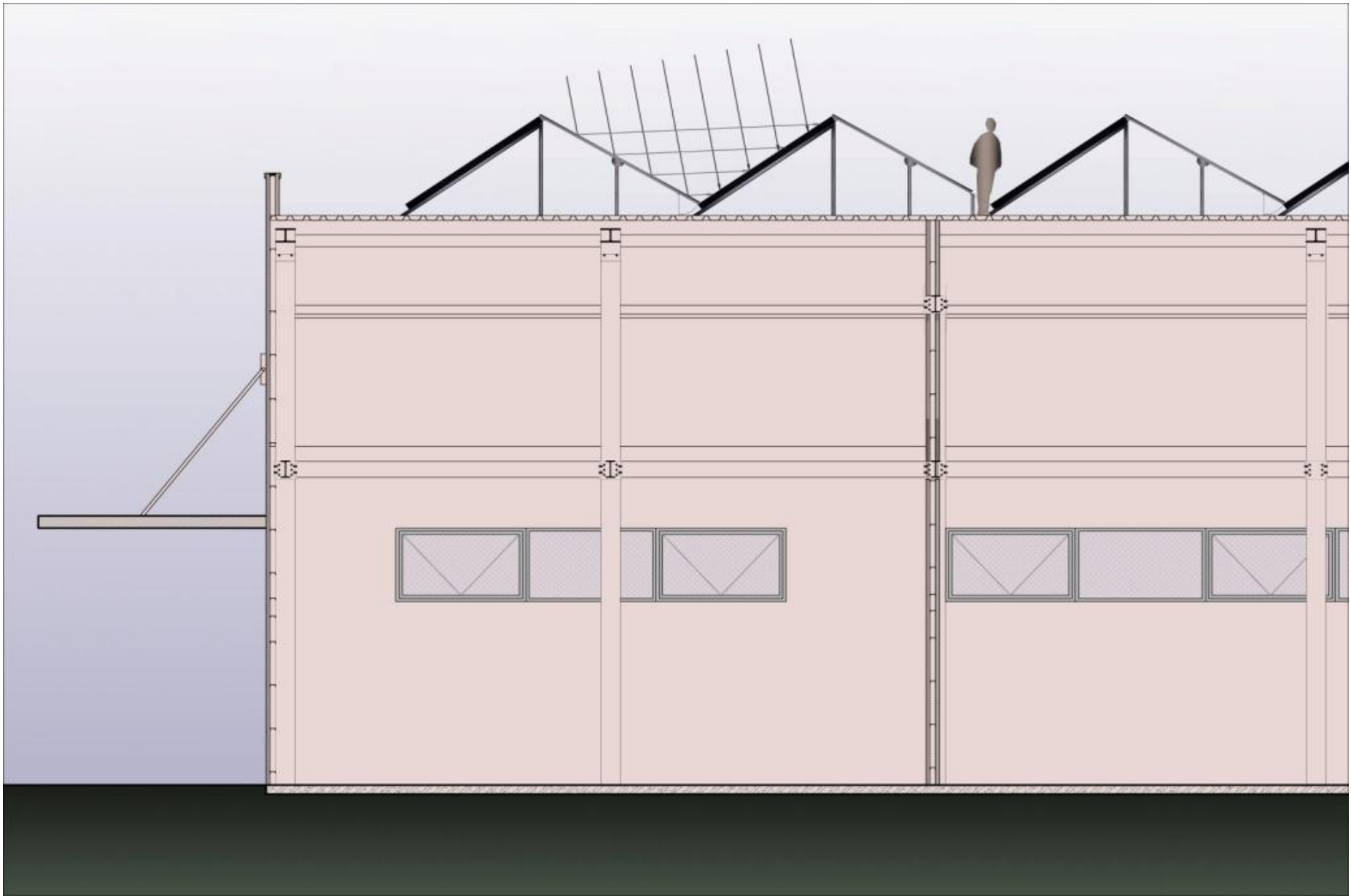

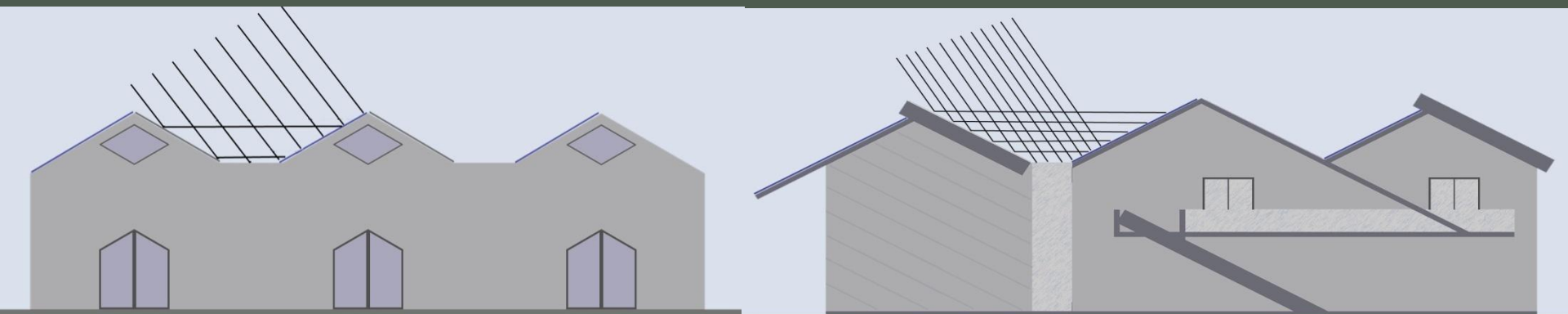
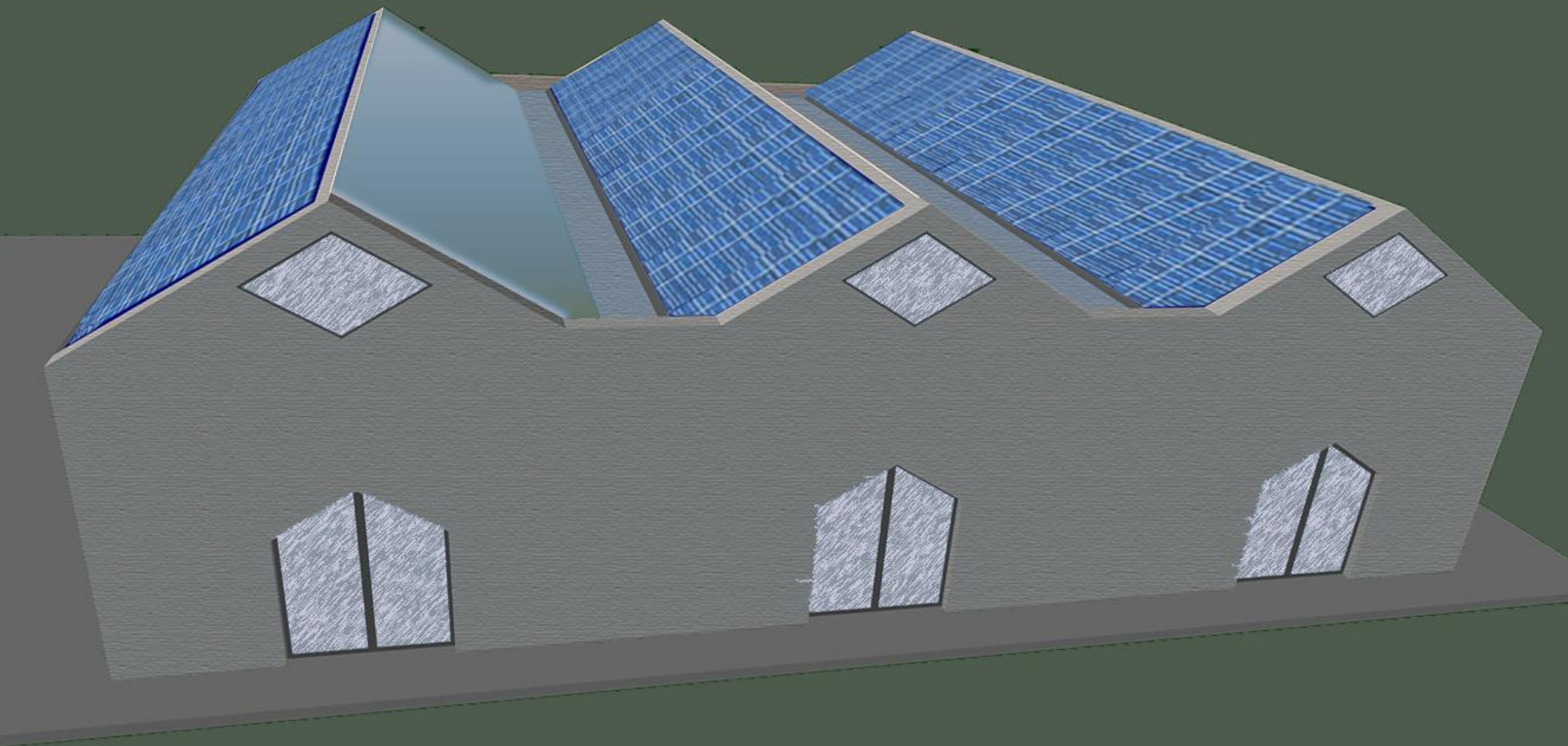

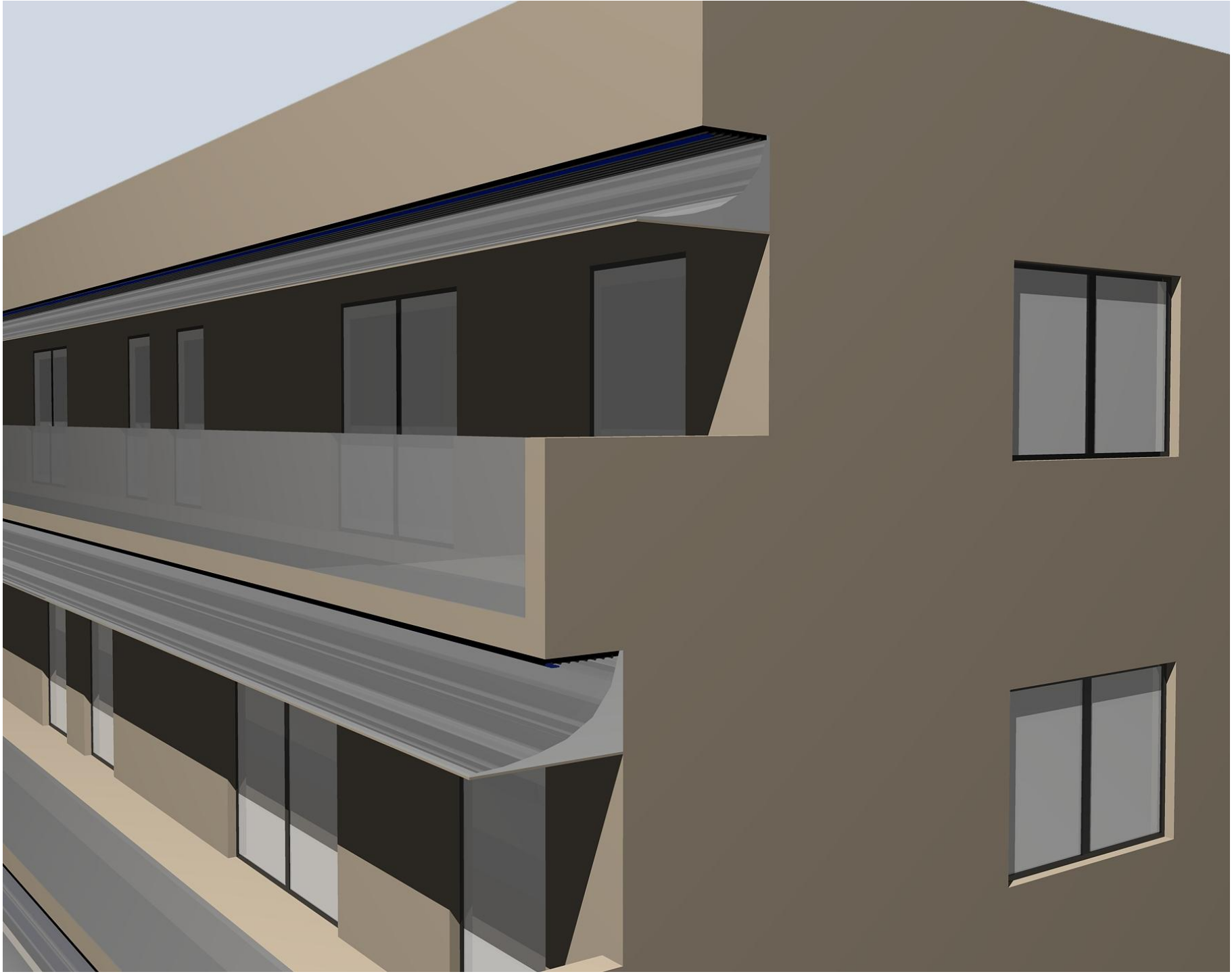

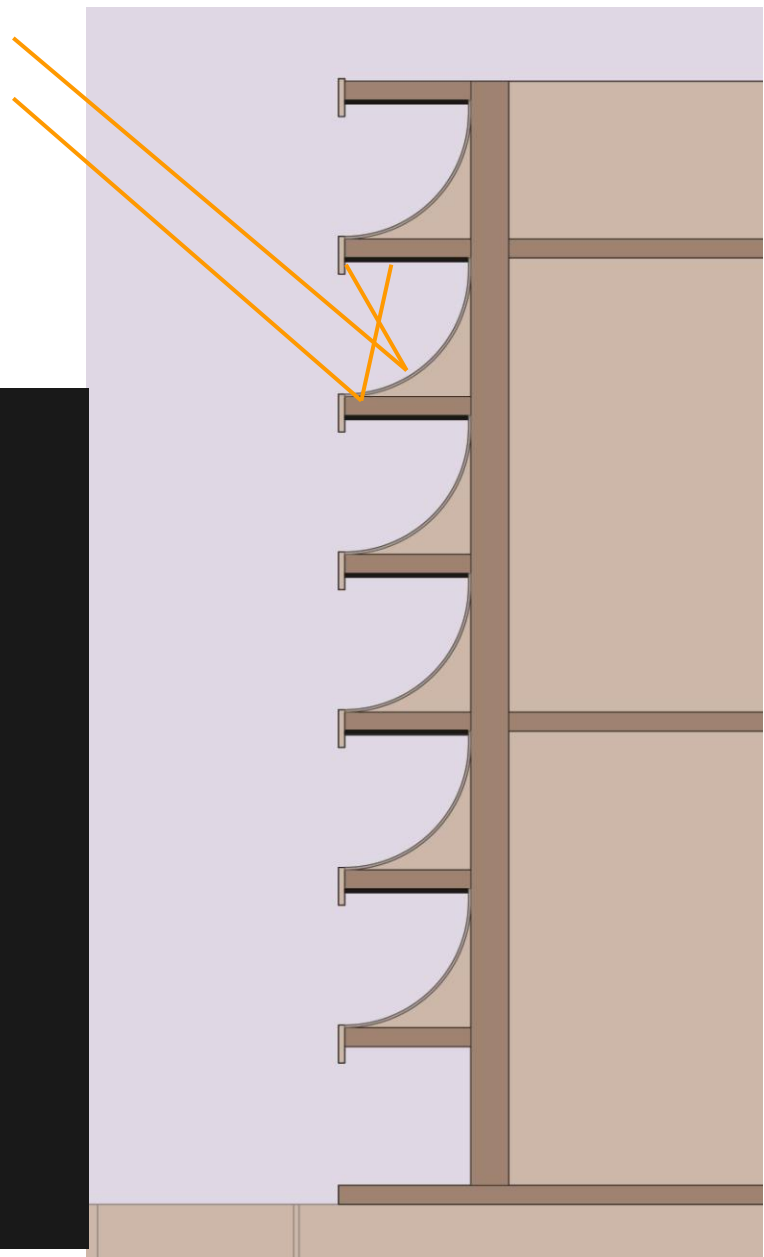
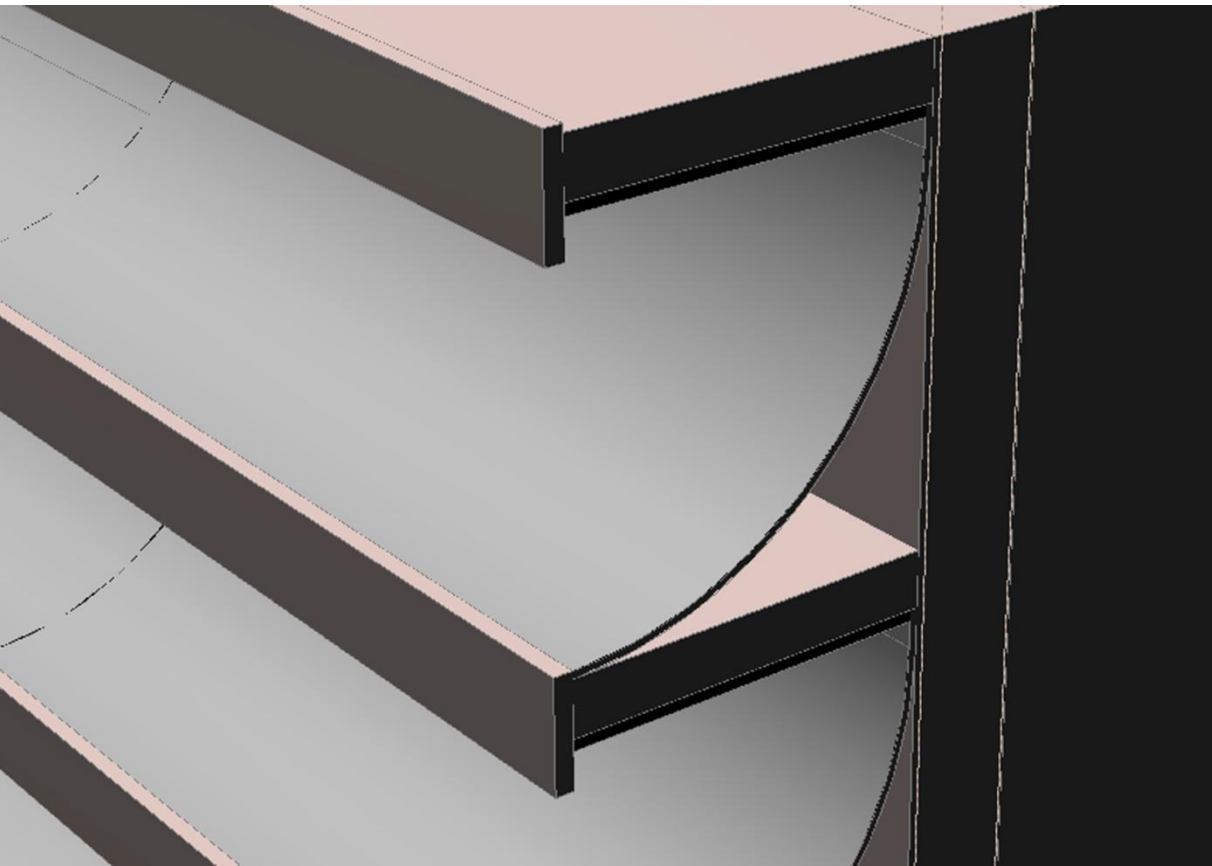

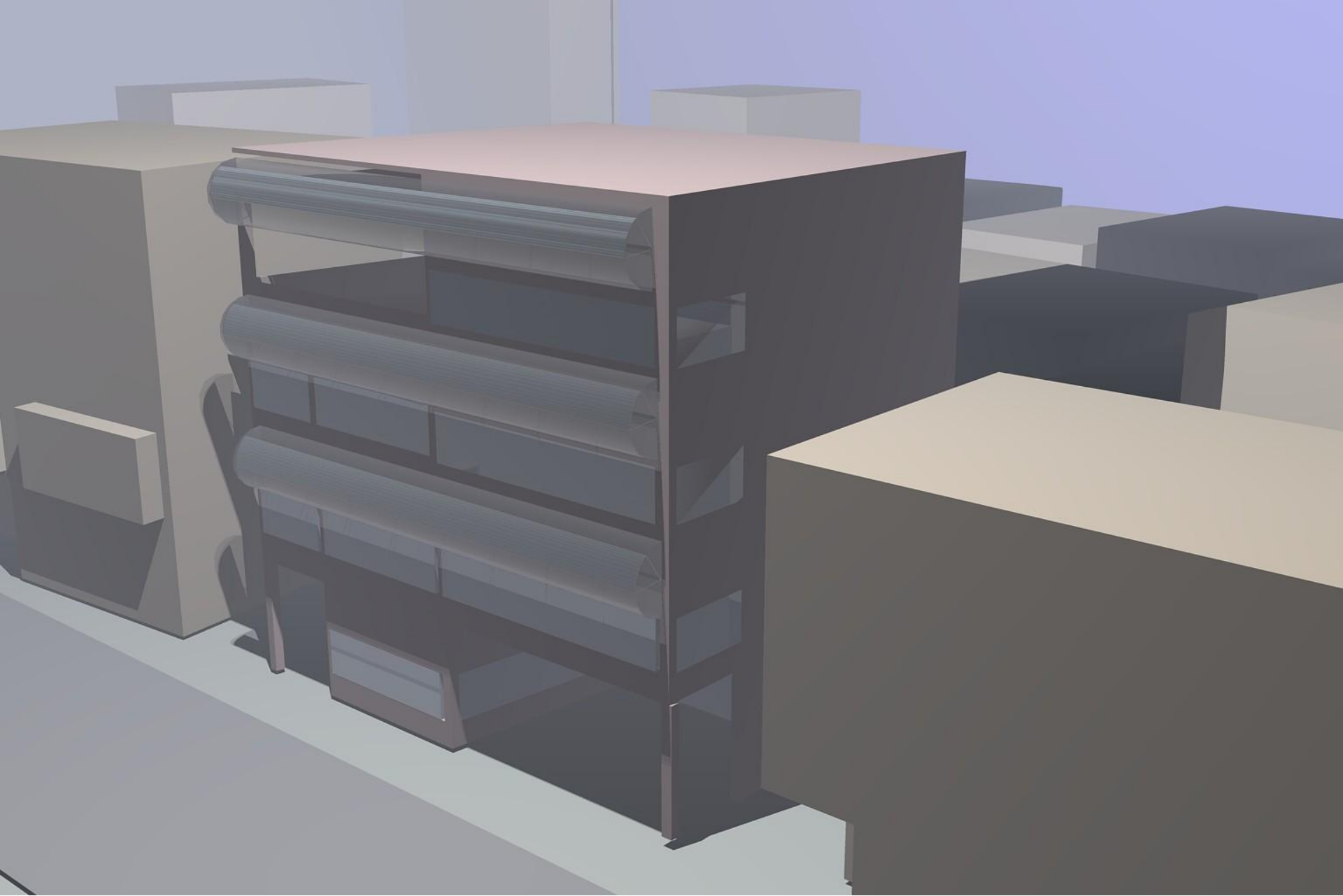

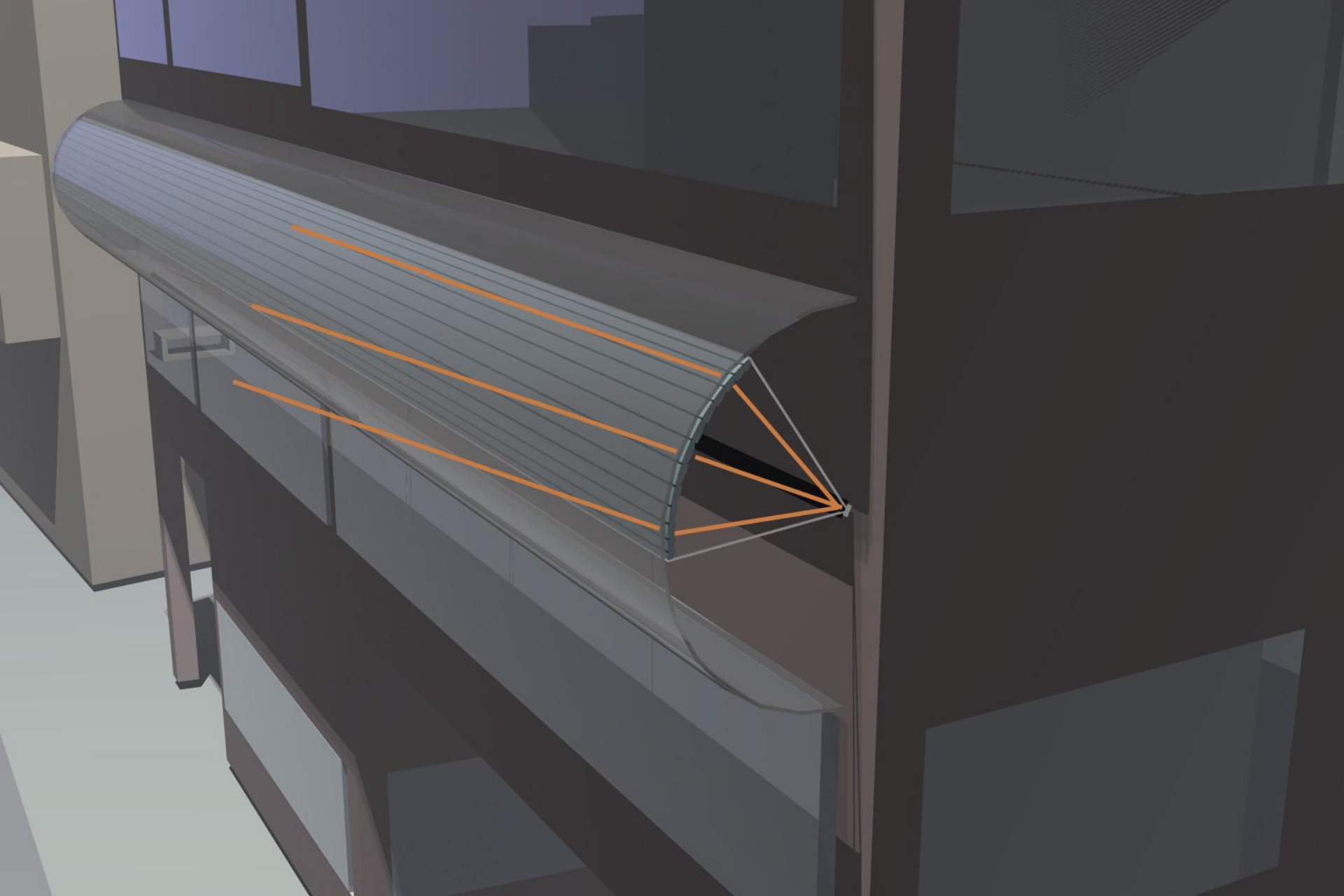

block of flats in Greece

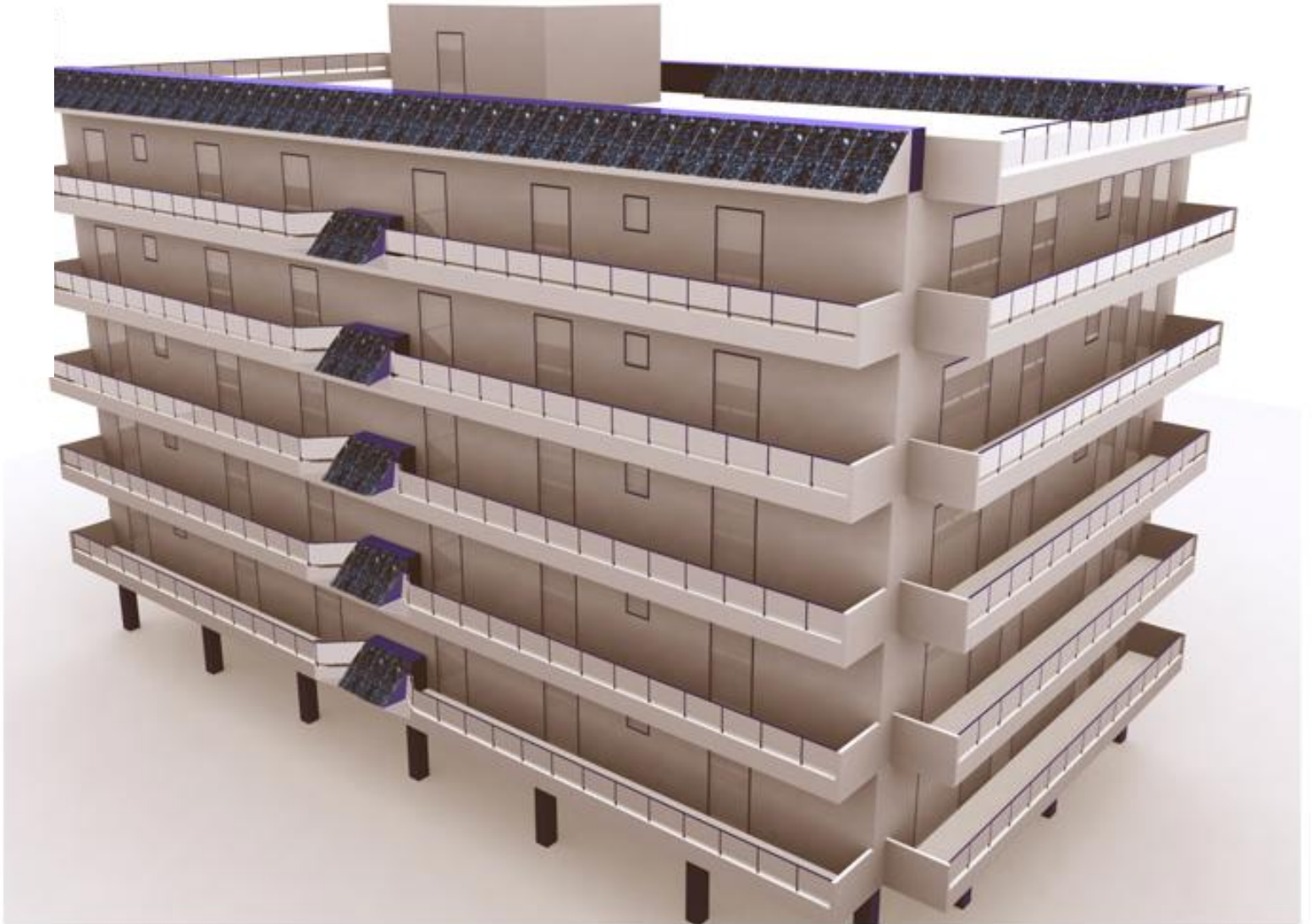

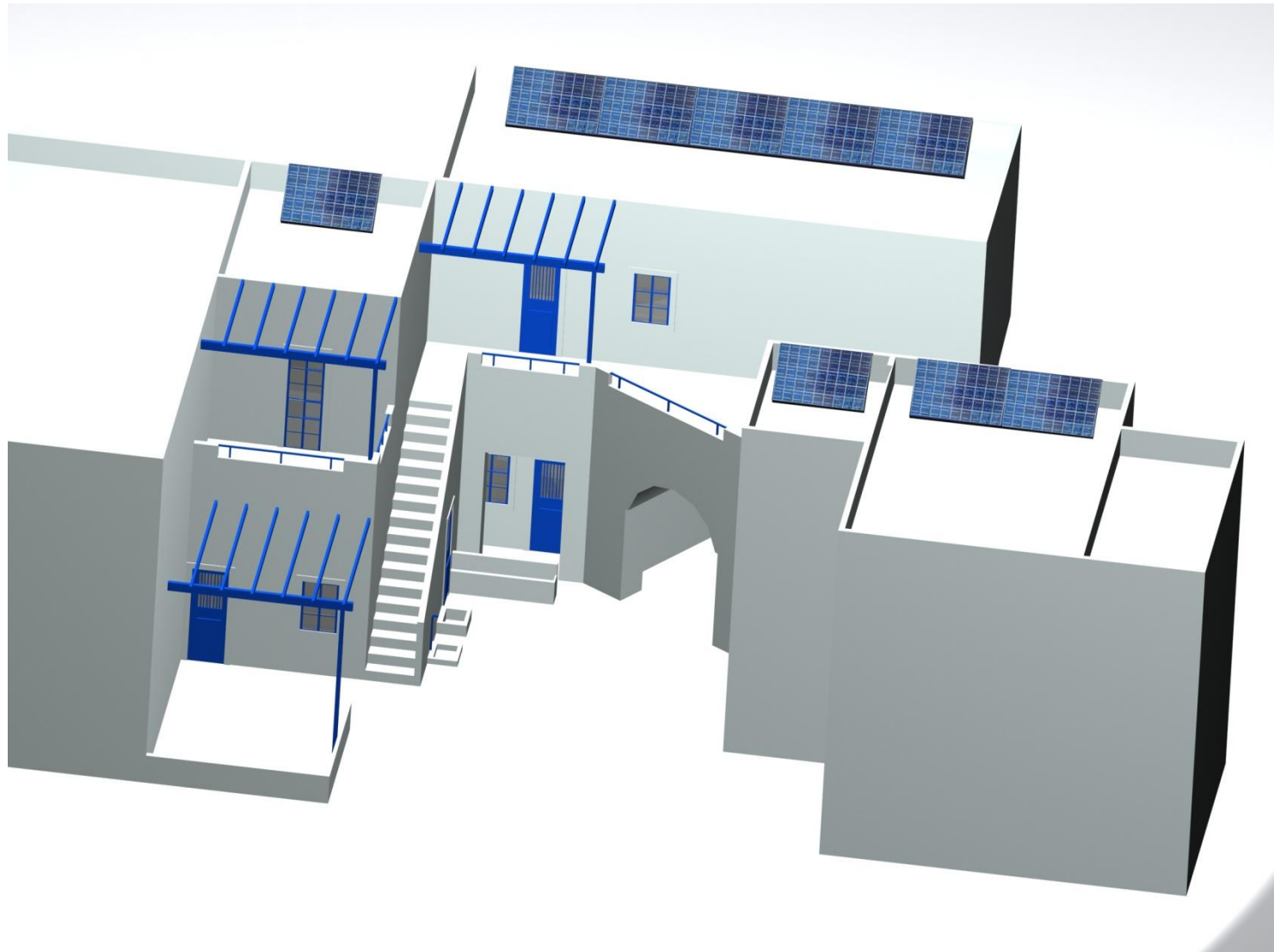

HYBRID PV/T COLLECTORS ON CYCLADIC HOUSE ROOF

Traditional settlements at Cycladic islands

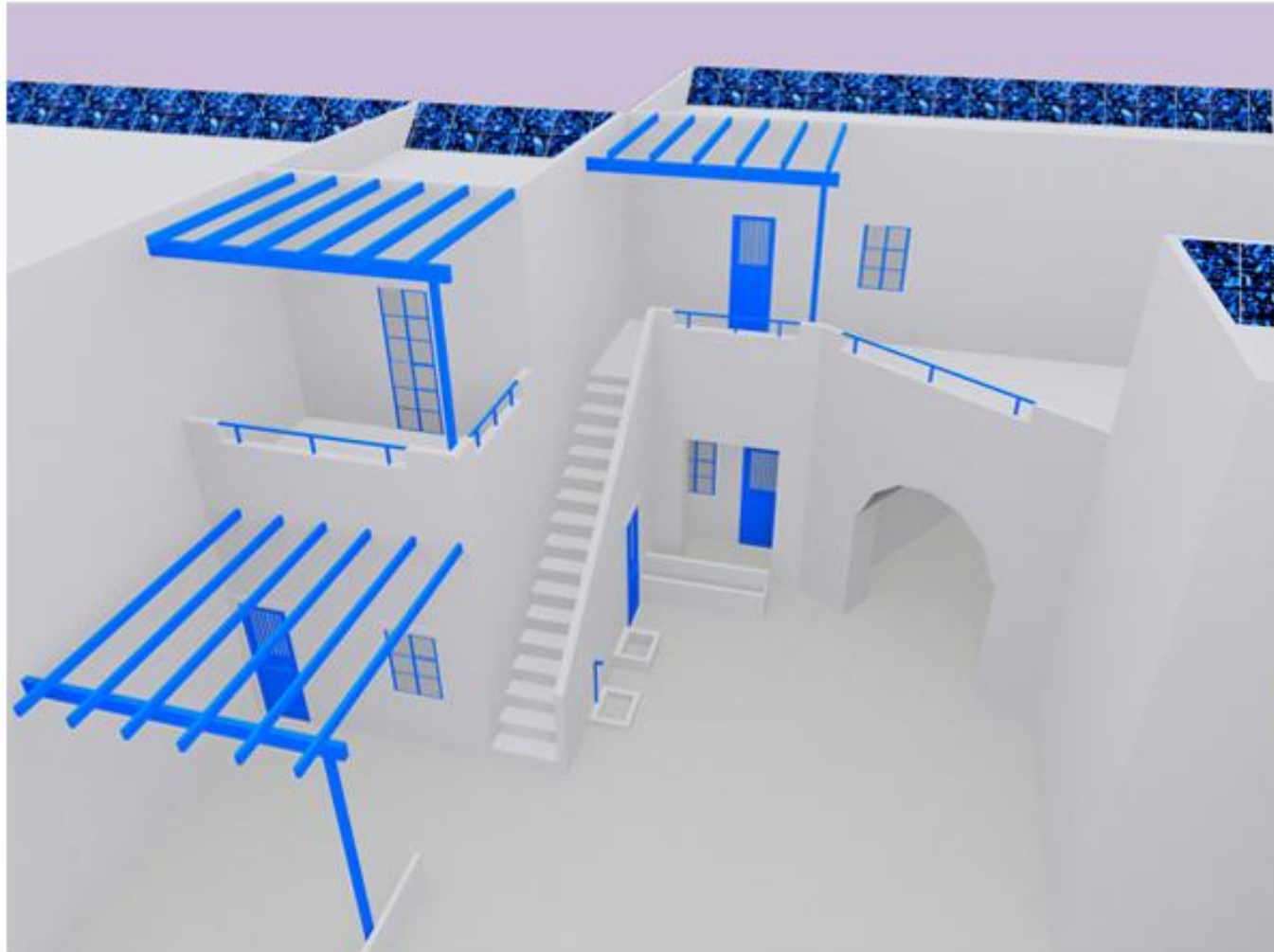

photovoltaic
panels may be
placed at the
roof of the
houses

series of photovoltaic panels could be integrated to the pergola

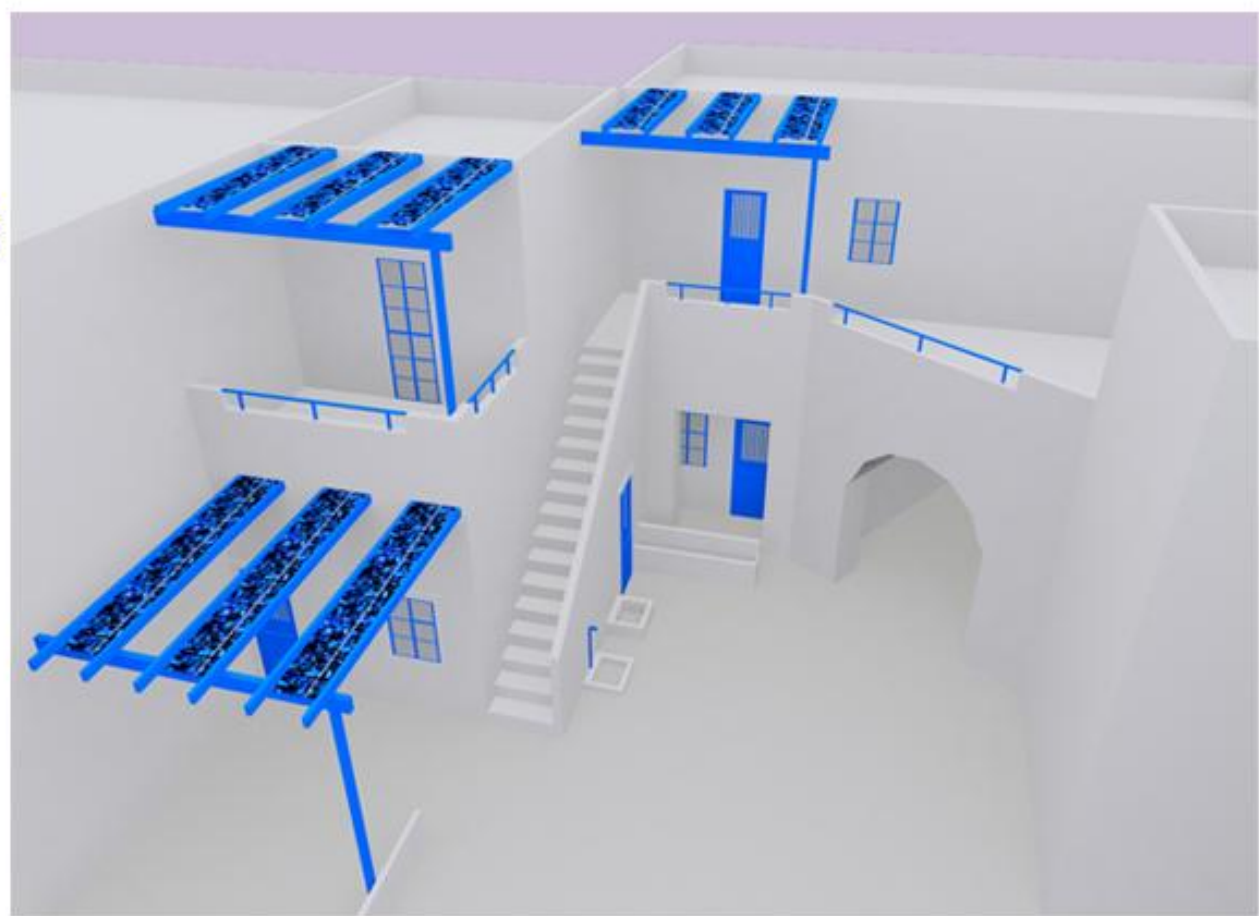

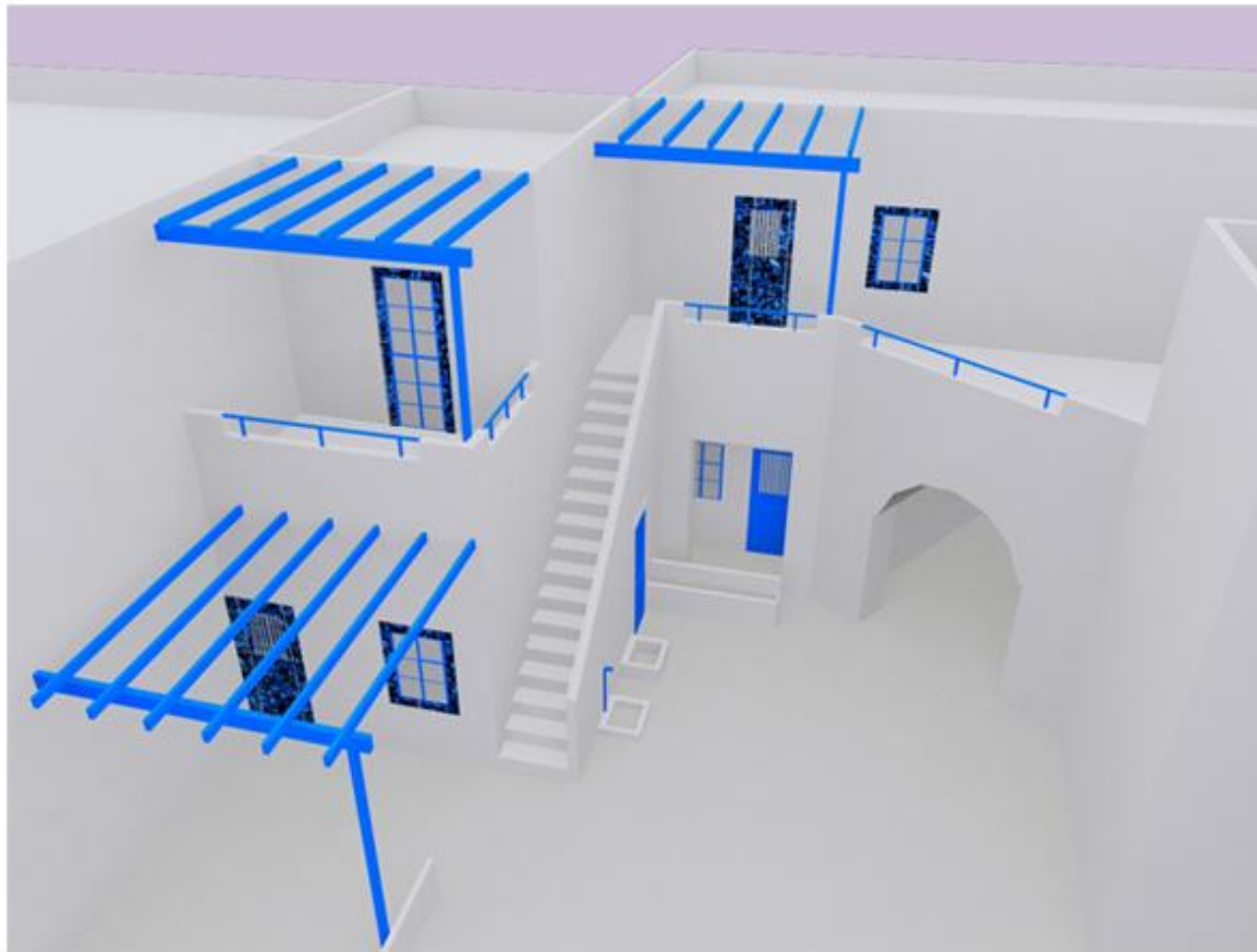

**the
photovoltaic
integration to
the doors and
the windows
of the house**



UPatras architectural design for cycladic island houses



Thank you for your attention
Ευχαριστώ για την προσοχή σας